

Carl Dietz
Gary Dietz

PERFORMANCE and SPECIFICATIONS

	172	SKYHAWK (172)	POWERMATIC (P172)	SKYHAWK POWERMATIC (P172)
GROSS WEIGHT	2300 lbs	2300 lbs	2500 lbs	2500 lbs
SPEED:				
Top Speed at Sea Level	138 mph	139 mph	146 mph	148 mph
Cruise, 75% Power at 7000 ft	130 mph	131 mph	138 mph	140 mph
RANGE:				
Cruise, 75% Power at 7000 ft	550 miles	555 miles	540 miles	545 miles
36 Gal., No Reserve (172)	4.2 hours	4.2 hours	3.9 hours	3.9 hours
41.5 Gal., No Reserve (P172)	130 mph	131 mph	138 mph	140 mph
Optimum Range at 10,000 ft.	670 miles	670 miles	610 miles	615 miles
36 Gal., No Reserve (172)	6.6 hours	6.6 hours	5.1 hours	5.1 hours
41.5 Gal., No Reserve (P172)	102 mph	102 mph	120 mph	121 mph
RATE-OF-CLIMB AT SEA LEVEL	645 fpm	645 fpm	830 fpm	830 fpm
SERVICE CEILING	13,100 ft	13,100 ft	17,000 ft	17,000 ft
TAKE-OFF:				
Ground Run	865 ft	865 ft	600 ft	600 ft
Total Distance Over 50-Foot Obstacle	1525 ft	1525 ft	1205 ft	1205 ft
LANDING:				
Landing Roll	520 ft	520 ft	610 ft	610 ft
Total Distance Over 50-Foot Obstacle	1250 ft	1250 ft	1200 ft	1200 ft
EMPTY WEIGHT (Approximate)	1260 lbs	1330 lbs	1360 lbs	1425 lbs
BAGGAGE	120 lbs	120 lbs	120 lbs	120 lbs
WING LOADING: Pounds/Sq Foot	13.2	13.2	14.4	14.4
POWER LOADING: Pounds/HP	15.9	15.9	14.3	14.3
FUEL CAPACITY: Total	39 gal.	39 gal.	52 gal.	52 gal.
OIL CAPACITY: Total	8 qts	8 qts	10 qts	10 qts
PROPELLER DIAMETER	76 in.	76 in.	84 in.	84 in.
PROPELLER TYPE	Fixed Pitch	Fixed Pitch	Constant Speed	Constant Speed
POWER:				
Continental Engine	O-300-C	O-300-D	GO-300-E	GO-300-E
Horsepower	145	145	175	175

Congratulations

Welcome to the ranks of Cessna owners! Your Cessna has been designed and constructed to give you the most in performance, economy, and comfort. You will find flying it, either for business or pleasure, a pleasant and profitable experience.

This Owner's Manual has been prepared as a guide to help you get the most pleasure and utility from your airplane. It contains information about your Cessna's equipment, operating procedures, and performance; and suggestions for its servicing and care. We urge you to read it from cover to cover, and to refer to it frequently.

Our interest in your flying pleasure has not ceased with your purchase of a Cessna. World-wide, the Cessna Dealer Organization backed by the Cessna Service Department stands ready to serve you. The following services are offered only by your Cessna Dealer:

- 1 FACTORY TRAINED MECHANICS to provide you with courteous expert service.
- 2 FACTORY APPROVED SERVICE EQUIPMENT to provide you with the most efficient and accurate workmanship possible.
- 3 A STOCK OF GENUINE CESSNA SERVICE PARTS on hand when you need them.
- 4 THE LATEST AUTHORITATIVE INFORMATION FOR SERVICING CESSNA AIRPLANES, since Cessna Dealers have all of the Service Manuals and Parts Catalogs, kept current by Service Letters and Service News Letters published by Cessna Aircraft Company.

We urge all Cessna owners to use the Cessna Dealer Organization to the fullest.

A current Cessna Dealer Directory accompanies your new airplane. The Directory is revised frequently, and a current copy can be obtained from your Cessna Dealer. Make your Directory one of your cross-country flight planning aids; a warm welcome awaits you at every Cessna Dealer.

TABLE OF CONTENTS

	Page
SECTION I – DESCRIPTION	1-1
SECTION II – OPERATING CHECK LIST	2-1
SECTION III – OPERATING DETAILS	3-1
SECTION IV – OPERATING LIMITATIONS	4-1
SECTION V – CARE OF THE AIRPLANE	5-1
DEALER FOLLOW-UP SYSTEM	5-6
SECTION VI – OPERATIONAL DATA	6-1
SECTION VII – OPTIONAL SYSTEMS	7-1
AUXILIARY FUEL TANK SYSTEM....	7-1
ALPHABETICAL INDEX.....	Index-1

This manual describes the operation and performance of Cessna Models 172, SKYHAWK, POWERMATIC, and SKYHAWK POWERMATIC. Where data applies to a specific model, it will be noted as follows: "(172)" for the Models 172 and SKYHAWK; "(P172)" for the POWERMATIC and SKYHAWK POWERMATIC. Equipment described as "optional" indicates that it is optional on the 172 and POWERMATIC models. Much of this equipment is standard on the SKYHAWK and SKYHAWK POWERMATIC models.

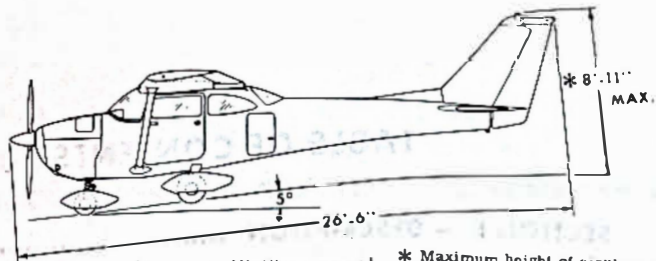

* Maximum height of airplane with nose gear depressed and an optional rotating beacon installed.

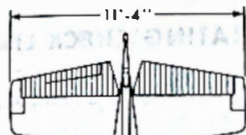

PRINCIPAL DIMENSIONS

172
and Skyhawk

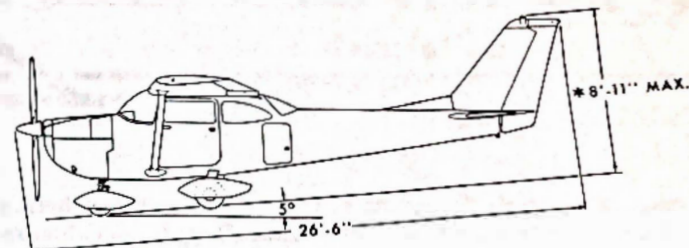
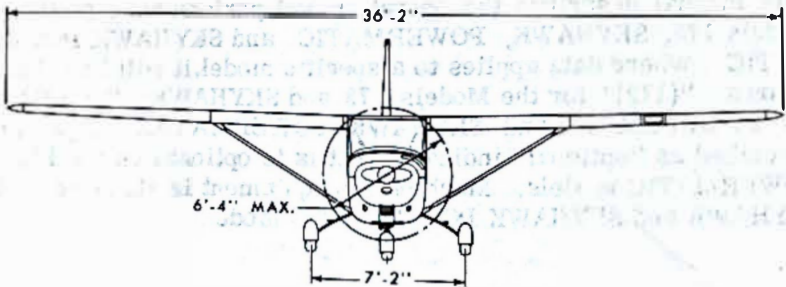
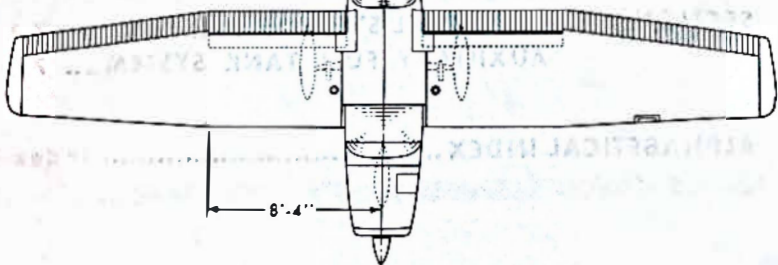

* Maximum height of airplane with nose gear depressed and an optional rotating beacon installed.



PRINCIPAL DIMENSIONS

Powermatic
and Skyhawk
Powermatic

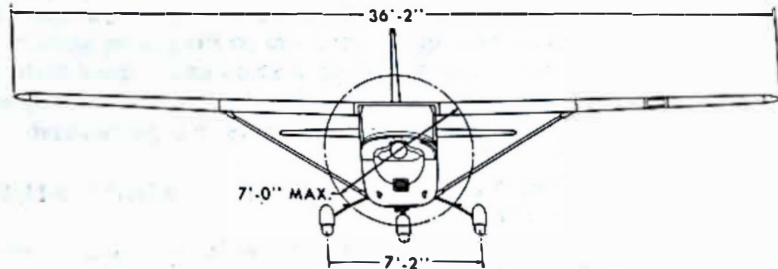
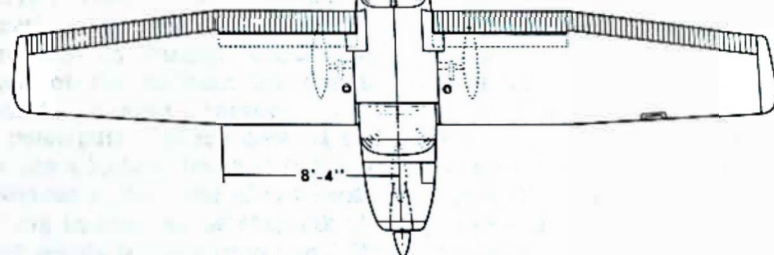

Section 1



description

One of the first steps in obtaining the utmost performance, service, and flying enjoyment from your Cessna is to familiarize yourself with your airplane's equipment, systems, and controls. This can best be done by reviewing this equipment while sitting in the airplane. Those items whose function and operation are not obvious are covered herein.

ENGINE CONTROLS.

THROTTLE AND MIXTURE CONTROLS.

The throttle is the push-pull type. A knurled friction-type locknut is incorporated on the throttle to secure it in any desired setting. Clockwise rotation of the locknut increases friction to prevent creeping.

The push-pull mixture control incorporates a locking lever to prevent inadvertent pulling out of the knob, resulting in leaning or shutting off the fuel supply in the carburetor. To lean the mixture, depress the locking lever while pulling out on the mixture control knob. The control knob may be pushed in, for rich mixture, without depressing the lever.

PROPELLER CONTROL. (P172)

The propeller control is the push-pull type and changes the setting of the propeller governor to control engine speed. The control may be

moved through its full range by depressing a locking button in the center of the knob, while minor adjustments are made by releasing the locking button and rotating the knob, clockwise to increase RPM or counterclockwise to decrease it.

For all ground operations, and for take-off, the propeller control should be full in (high RPM). After take-off, reduce throttle first, then reduce RPM. Since a small control movement will produce a considerable RPM change, you should set up climb and cruise RPM by screwing the knob in or out.

Propeller surging (RPM variation up and down several times before engine smooths out and becomes steady) can be prevented by smooth throttle and propeller control knob operation. Do not change the throttle and propeller control settings with jerky and rapid motions.

CARBURETOR AIR HEAT KNOB.

The carburetor air heat knob pro-

portions the hot and cold air entering the carburetor. Pulling the knob out provides heated air for the carburetor, while pushing it in decreases the temperature. The knob is the double-button type, and is operated by squeezing the buttons together to unlock the control prior to moving it.

STARTER HANDLE. (172 ONLY)

Pulling out on the "T" shaped starter handle engages the engine starter. It is spring loaded to return to the disengaged position when released.

NOTE

Don't pull out on the starter handle when the propeller is turning, as damage to the starter drive may result.

IGNITION SWITCH. (172 ONLY)

The ignition switch is a conventional, key operated, four position switch, labeled clockwise: "OFF," "R," "L," and "BOTH."

IGNITION-STARTER SWITCH. (SKYHAWK & P172)

The key-operated switch controls the magneto ignition system and functions as a starter switch. The switch has five positions labeled clockwise "OFF," "R," "L," "BOTH" and "START." The switch is spring-loaded in the "START" position and will return to the "BOTH" position when the key is released.

COWL FLAPS (P172)

Cowl flaps, adjusted to the need, will meter enough air for the adequate cooling and maximum efficiency of the engine under varying conditions. Opening the cowl flaps, while on the ground, steps up the volume of air necessary for engine cooling. In flight, closing the cowl flaps, as required, restricts the flow of air through the engine compartment, thereby reducing the cooling and cowl flap drag to a minimum. When the cowl flap control is full in the cowl flaps are fully open. When the control is pulled out to its limit, the cowl flaps are closed. The cowl flap control knob is the double button type, with a friction lock, to permit intermediate settings.

FUEL SYSTEM.

Fuel is supplied to the engine from two aluminum tanks, one in each wing. From these tanks, fuel flows by gravity through a selector valve and a strainer to the carburetor.

Refer to figure 1-2 for fuel quantity data. See the Servicing Diagram (figure 5-1) for a summary of fuel system servicing information.

FUEL SELECTOR VALVE.

A rotary type fuel selector valve is located at the aft end of the cabin floor tunnel between the front seats. The valve has four positions which are labeled "BOTH OFF," "LEFT TANK," "RIGHT TANK," and "BOTH ON." The "BOTH OFF" position seals both wing tanks off from the

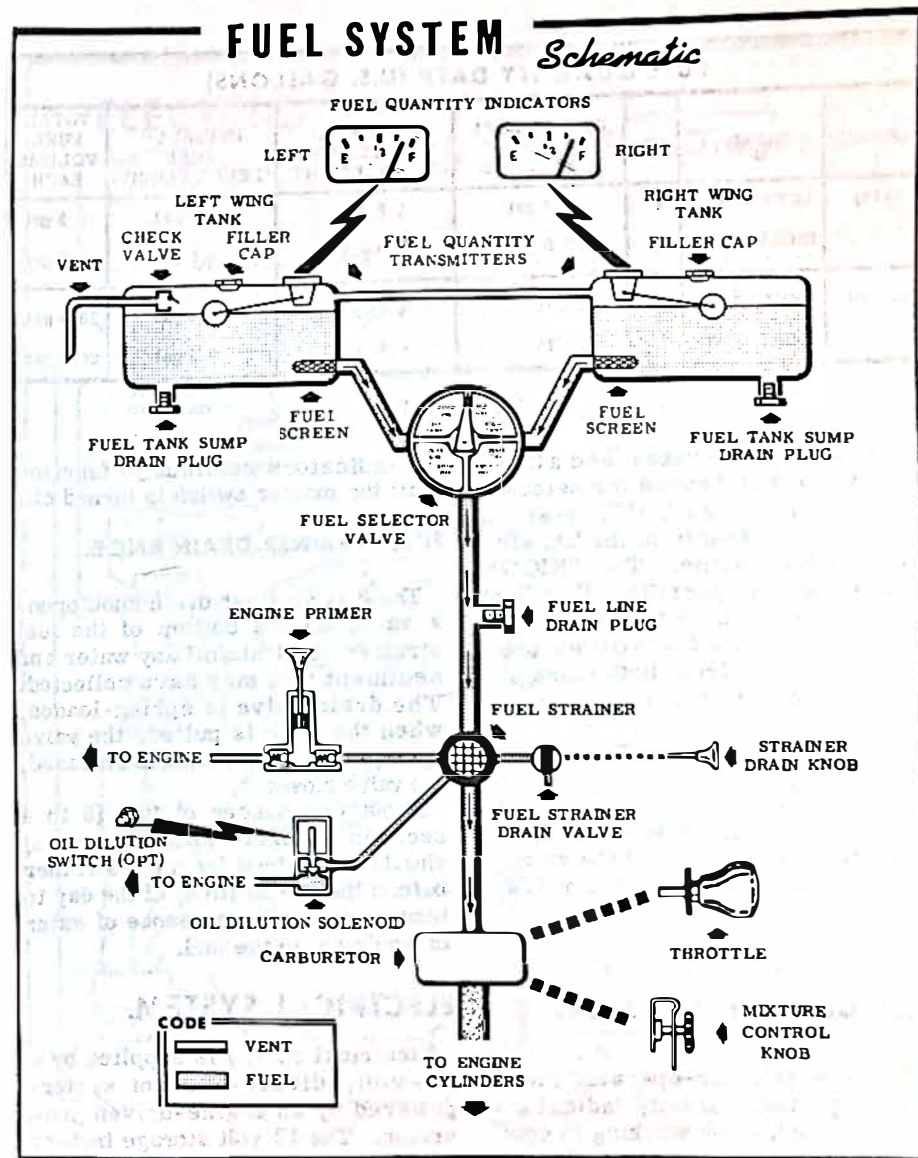

Figure 1-1.

FUEL QUANTITY DATA (U.S. GALLONS)						
MODEL	TANKS	NO.	USABLE FUEL ALL FLIGHT CONDITIONS	ADDITIONAL USABLE FUEL (LEVEL FLIGHT)	UNUSABLE FUEL (LEVEL FLIGHT)	TOTAL FUEL VOLUME EACH
(172)	LEFT WING	1	18.0 gal.	1.0 gal.	0.5 gal.	19.5 gal.
	RIGHT WING	1	18.0 gal.	1.0 gal.	0.5 gal.	19.5 gal.
(P172)	LEFT WING	1	20.75 gal.	4.75 gal.	0.5 gal.	26.0 gal.
	RIGHT WING	1	20.75 gal.	4.75 gal.	0.5 gal.	26.0 gal.

Figure 1-2.

rest of the fuel system and allows no fuel to pass beyond the selector valve. The "LEFT TANK" position allows fuel to flow from the left wing tank to the engine. The "RIGHT TANK" position permits fuel to flow from the right wing tank to the engine. The "BOTH ON" position provides fuel flow from both tanks simultaneously to provide maximum safety.

NOTE

The fuel selector valve handle indicates the setting of the valve by its position above the valve dial.

FUEL QUANTITY INDICATORS.

Two electrically-operated magnetic type fuel quantity indicators are provided, each working in conjunction with an electric fuel level transmitter in its respective fuel tank. Turned on by the master switch

the indicators continue to function until the master switch is turned off.

FUEL STRAINER DRAIN KNOB.

The fuel strainer drain knob opens a valve on the bottom of the fuel strainer, to drain off any water and sediment that may have collected. The drain valve is spring-loaded; when the knob is pulled, the valve opens, and when the knob is released, the valve closes.

About two ounces of fuel (3 to 4 seconds of drain knob operation) should be drained from the strainer before the initial flight of the day to insure against the presence of water or sediment in the fuel.

ELECTRICAL SYSTEM.

Electrical energy is supplied by a 12-volt, direct-current system powered by an engine-driven generator. The 12-volt storage battery is located; on the left-hand forward portion of the firewall (172); or aft of the baggage curtain (P172).

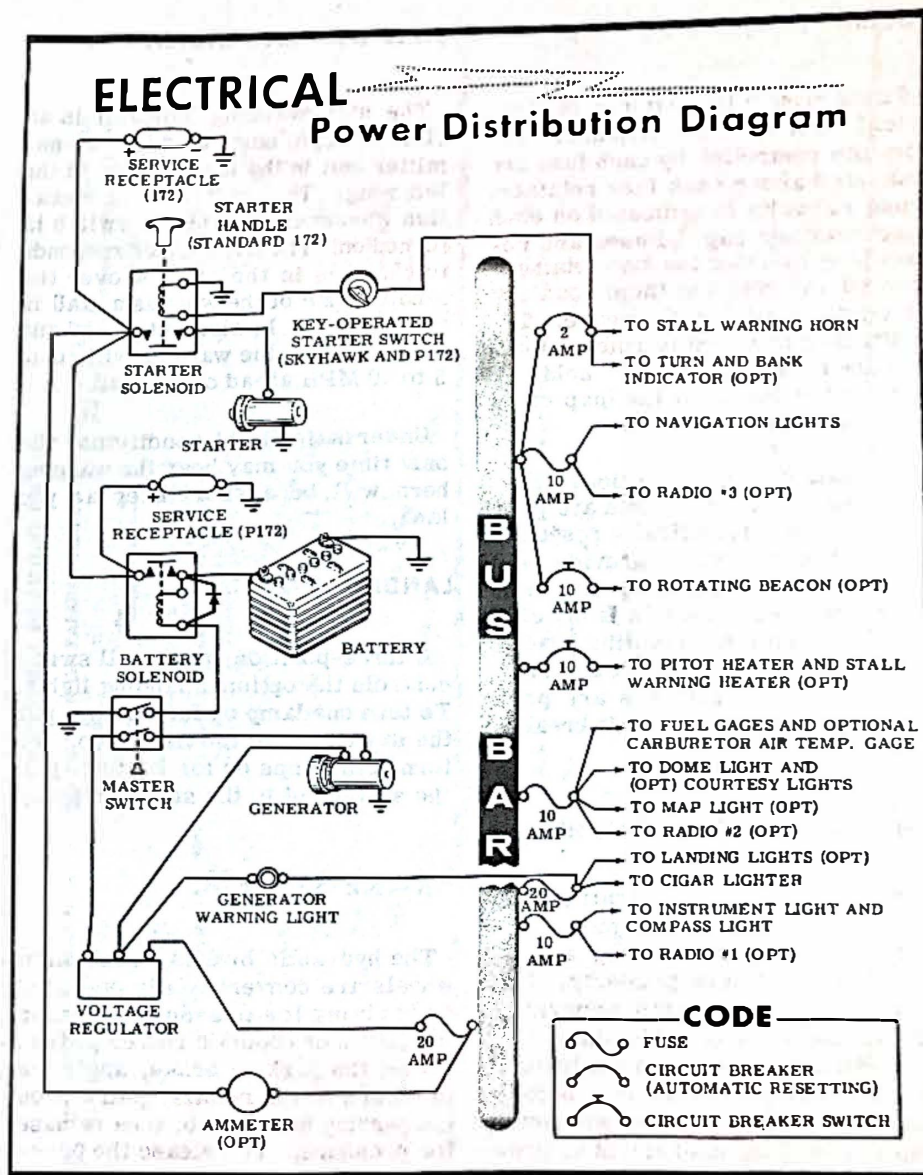

Figure 1-3.

FUSES.

Fuses protect the majority of electrical circuits in the airplane. The circuits controlled by each fuse are indicated above each fuse retainer. Fuse capacity is indicated on each fuse retainer cap. Fuses are removed by pressing the fuse retainers inward and rotating them counterclockwise until they disengage. The faulty fuse may then be lifted out and replaced. Spare fuses are held in a clip on the inside of the map compartment door.

The stall warning and optional turn-and-bank indicator circuits are protected by an automatically resetting circuit breaker which provides intermittent emergency operation of these devices in case of a faulty circuit. The optional rotating beacon system and optional pitot and stall warning heater systems are protected by separate circuit breaker switches.

GENERATOR WARNING LIGHT.

The red generator warning light indicates generator output. The light remains off as long as the generator functions properly. If a malfunction interrupts generator output, the light will illuminate. It also will illuminate when the battery or external power is on, before starting the engine, and whenever engine speed is insufficient to produce generator output. The light does not show battery drain.

STALL WARNING INDICATOR.

The stall warning indicator is an electric horn, controlled by a transmitter unit in the leading edge of the left wing. This system is in operation whenever the master switch is turned on. The transmitter responds to changes in the airflow over the leading edge of the wing as a stall is approached. In straight-ahead and turning flight, the warning will come 5 to 10 MPH ahead of the stall.

Under safe flight conditions, the only time you may hear the warning horn will be a short beep as you land.

LANDING LIGHTS.

A three-position, push-pull switch controls the optional landing lights. To turn one lamp on for taxiing, pull the switch out to the first stop. To turn both lamps on for landing, pull the switch out to the second stop.

BRAKE SYSTEM.

The hydraulic brakes on the main wheels are conventionally operated by applying toe pressure to either the pilot's or copilot's rudder pedals. To set the parking brake, apply toe pressure to the pedals, pull out on the parking brake knob, then release toe pressure. To release the parking brake, push the knob in, then apply and release toe pressure.

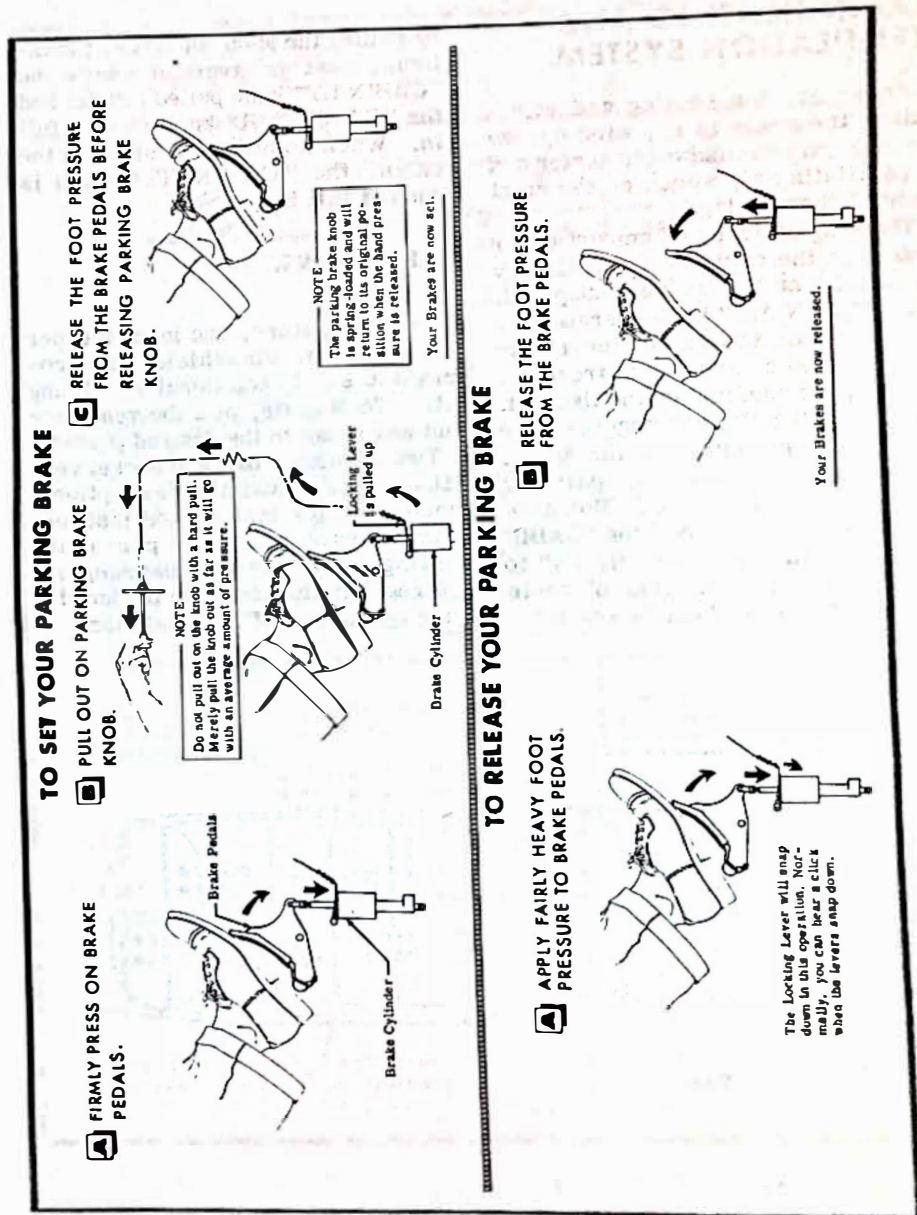

Figure 1-4.

CABIN HEATING AND VENTILATION SYSTEM.

Fresh air for heating and ventilating the cabin is supplied by two sources, a manifold cabin heater and a ventilating air scoop on the right side of the fuselage.

The temperature and amount of air entering the cabin is controlled by two knobs on the instrument panel. The "CABIN AIR" knob operates the air scoop on the right side of the fuselage and controls cool fresh air entering the manifold on the firewall. The "CABIN HT" knob regulates the amount of heat entering the cabin.

For cabin ventilation, pull the "CABIN AIR" knob out. To raise the air temperature, pull the "CABIN HT" knob out approximately 1/4" to 1/2" for a small amount of cabin heat. Additional heat is available

by pulling the knob out farther; maximum heat is available with the "CABIN HT" knob pulled full out and the "CABIN AIR" knob pushed full in. When no heat is desired in the cabin, the "CABIN HT" knob is pushed full in.

VENTILATORS.

Two ventilators, one in each upper corner of the windshield, are provided to supply additional ventilating air. To operate, pull the ventilator out and rotate to the desired position.

Two additional ball and socket ventilators are available as optional equipment for installation just forward of each rear door post in the ceiling, for rear seat passengers. To regulate the air, turn the knurled ring on the rim of the ventilator.

INTERNAL CABIN DIMENSIONS

DOOR OPENING DIMENSIONS

	WIDTH (TOP)	WIDTH (BOTTOM)	HEIGHT (FRONT)	HEIGHT (REAR)
CABIN DOOR	32"	37"	40 1/2"	38 1/2"
BAGGAGE DOOR	15 1/4"	15 3/4"	22 1/4"	21"

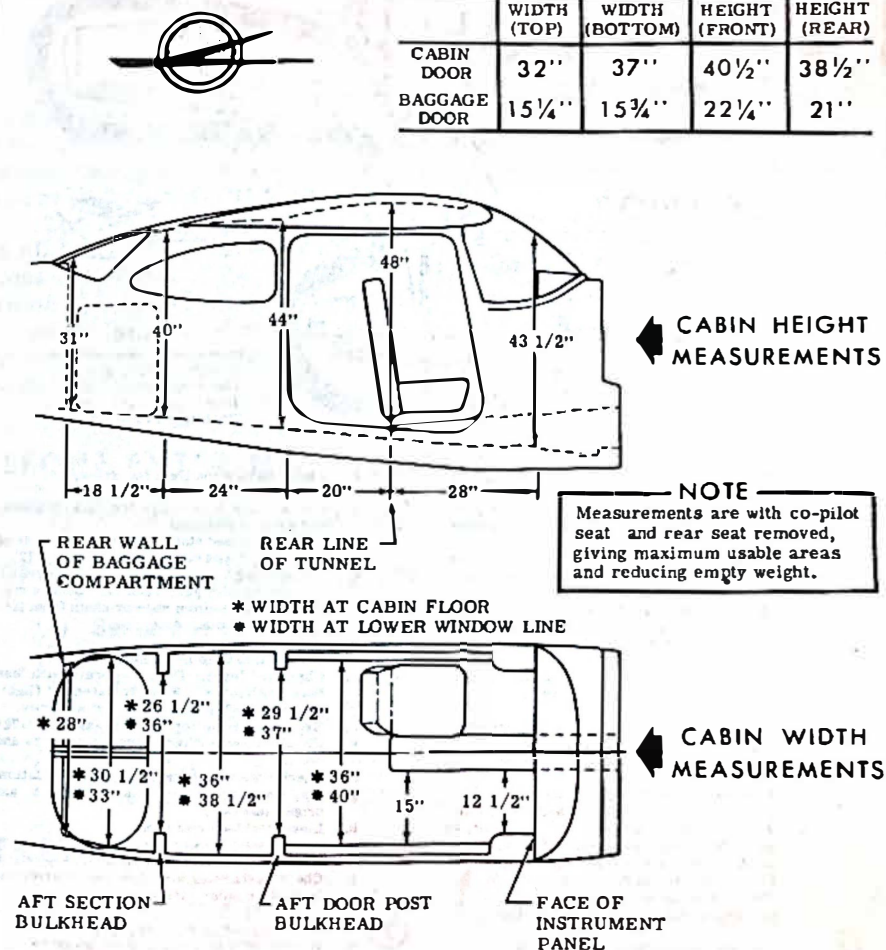

Figure 1-5.

Operating Check List

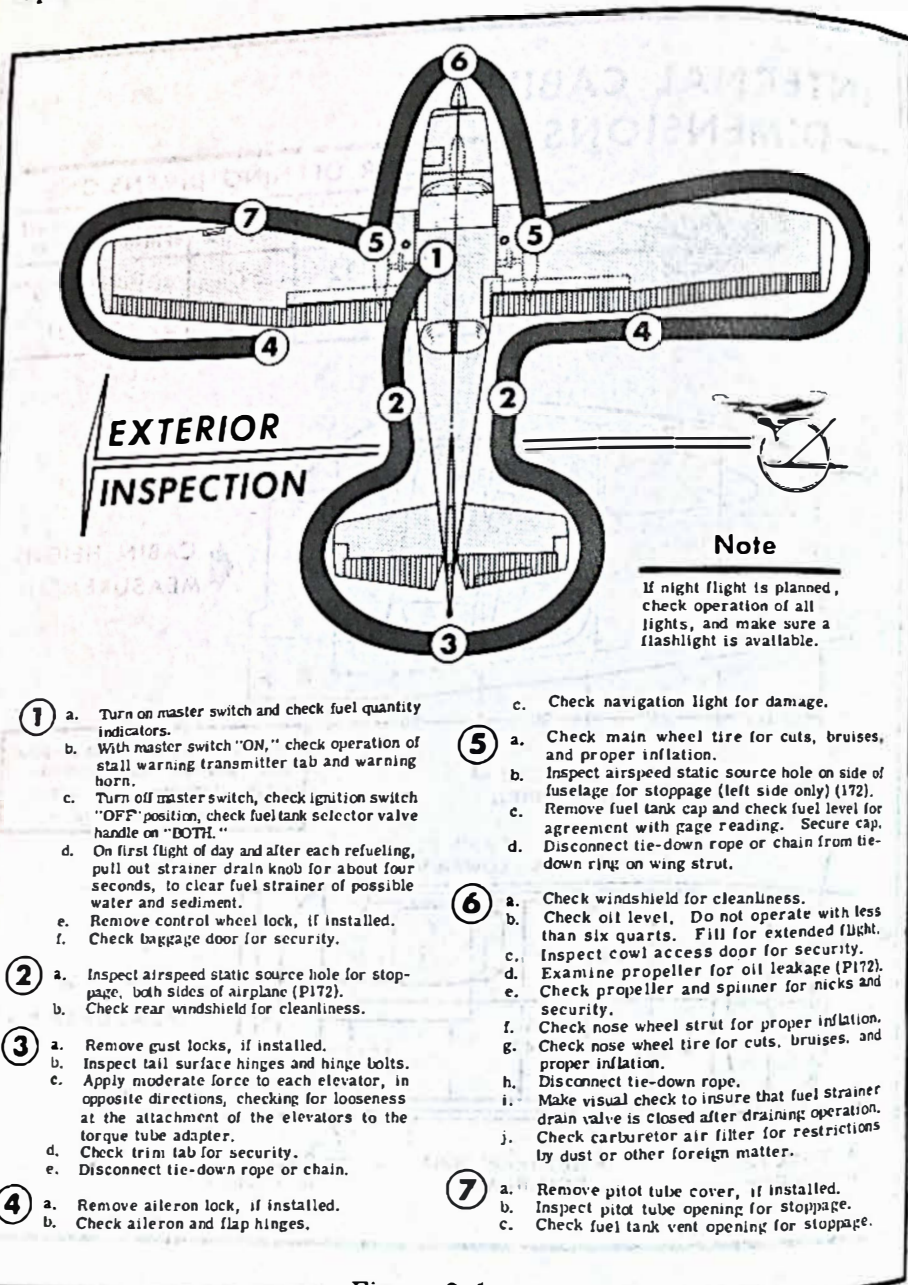

Figure 2-1.

section 2 operating check list

This section lists, in Pilot's Check List form, the steps necessary to operate your airplane efficiently and safely. It is not a check list in its true form as it is considerably longer, but it does cover briefly all of the points that you would want to or should know concerning the information you need for a typical flight.

The flight and operational characteristics of your airplane are normal in all respects. There are no "unconventional" characteristics or operations that need to be mastered. All controls respond in the normal way within the entire range of operation of the airplane. All airspeeds mentioned in Sections II and III are indicated airspeeds. Corresponding calibrated airspeeds may be obtained from the Airspeed Correction Table in Section VI.

BEFORE ENTERING THE AIRPLANE.

- (1) Make an exterior inspection in accordance with figure 2-1.

BEFORE STARTING THE ENGINE.

- (1) Seats and Seat Belts - Adjust and lock.
- (2) Flight Controls - Check.
- (3) Brakes - Test and set.
- (4) Master Switch - "ON."
- (5) Trim Tab - Set.
- (6) Fuel Selector - "BOTH ON."
- (7) Cowl Flaps - "OPEN." (P172)

STARTING THE ENGINE.

- (1) Carburetor Heat - Cold.
- (2) Mixture - Rich.
- (3) Propeller - High RPM (full in). (P172)
- (4) Primer - As required.
- (5) Ignition Switch - "BOTH."

- (6) Throttle - Open 1/8".
- (7) Propeller Area - Clear.
- (8) Starter - Engage.

BEFORE TAKE-OFF.

- (1) Throttle Setting: 1600 RPM (172),
1500 RPM (P172).
- (2) Engine Instruments - Within green arc.
- (3) Magnetos - Check (75 RPM maximum differential between magnetos).
- (4) Propeller - Cycle from high to low RPM; return to high RPM (full in) (P172).
- (5) Carburetor Heat - Check.
- (6) Cowl Flaps - "OPEN." (P172).
- (7) Flight Controls and Seat Latching - Recheck.
- (8) Wing Flaps - 0° or 10°.
- (9) Trim Tab - "TAKE-OFF."
- (10) Cabin Doors - Closed and locked.
- (11) Flight Instruments and Radios - Set.

TAKE-OFF.

NORMAL TAKE-OFF.

- (1) Flaps - Up.
- (2) Carburetor Heat - Cold.
- (3) Power - Full throttle (applied smoothly).
- (4) Elevator Control - Lift nosewheel at 60 MPH.
- (5) Climb Speed - 85 MPH.

MAXIMUM PERFORMANCE TAKE-OFF.

- (1) Flaps: Up (172),
10° (P172).
- (2) Carburetor Heat - Cold.
- (3) Brakes - Apply.
- (4) Power - Full throttle.
- (5) Brakes - Release.
- (6) Elevator Control - Slightly tail low.

- (7) Climb Speed: 65 MPH (172),
55 MPH (P172).

CLIMB.

NORMAL CLIMB.

- (1) Airspeed: 80 to 90 MPH (172),
90 to 100 MPH (P172).
- (2) Power: Full throttle (172),
23 inches and 2250 RPM (P172).
- (3) Mixture: Full rich (unless engine is rough).
- (4) Cowl Flaps - "OPEN" (P172).

MAXIMUM PERFORMANCE CLIMB.

- (1) Airspeed - 80 MPH at sea level to 77 MPH at 10,000 feet (172),
85 MPH at sea level to 83 MPH at 10,000 feet (P172).
- (2) Power: Full throttle (172),
Full throttle and 2400 RPM (P172).
- (3) Mixture - Full rich unless engine is rough.
- (4) Cowl Flaps - "OPEN" (P172).

CRUISING.

- (1) Power: 2200 to 2700 RPM (172),
2000 to 2250 RPM and 15-23 inches Hg. (P172).
- (2) Trim Tab - Adjust.
- (3) Mixture - Lean.

LET-DOWN.

- (1) Mixture - Rich.
- (2) Power - As desired.
- (3) Carburetor Heat - As required to prevent carburetor icing.

BEFORE LANDING.

- (1) Fuel Selector - "BOTH ON."
- (2) Mixture - Rich.
- (3) Propeller - High RPM (full in). (P172)
- (4) Airspeed - 70 - 80 MPH (flaps up).

Operating Check List

- (6) Throttle - Open 1/8".
- (7) Propeller Area - Clear.
- (8) Starter - Engage.

BEFORE TAKE-OFF.

- (1) Throttle Setting: 1600 RPM (172),
1500 RPM (P172).
- (2) Engine Instruments - Within green arc.
- (3) Magnetos - Check (75 RPM maximum differential between magnetos).
- (4) Propeller - Cycle from high to low RPM; return to high RPM (full in) (P172).
- (5) Carburetor Heat - Check.
- (6) Cowl Flaps - "OPEN." (P172).
- (7) Flight Controls and Seat Latching - Recheck.
- (8) Wing Flaps - 0° or 10°.
- (9) Trim Tab - "TAKE-OFF."
- (10) Cabin Doors - Closed and locked.
- (11) Flight Instruments and Radios - Set.

TAKE-OFF.

NORMAL TAKE-OFF.

- (1) Flaps - Up.
- (2) Carburetor Heat - Cold.
- (3) Power - Full throttle (applied smoothly).
- (4) Elevator Control - Lift nosewheel at 60 MPH.
- (5) Climb Speed - 85 MPH.

MAXIMUM PERFORMANCE TAKE-OFF.

- (1) Flaps: Up (172),
10° (P172).
- (2) Carburetor Heat - Cold.
- (3) Brakes - Apply.
- (4) Power - Full throttle.
- (5) Brakes - Release.
- (6) Elevator Control - Slightly tail low.

Operating Check List

- (7) Climb Speed: 65 MPH (172),
55 MPH (P172).

CLIMB.

NORMAL CLIMB.

- (1) Airspeed: 80 to 90 MPH (172),
90 to 100 MPH (P172).
- (2) Power: Full throttle (172),
23 inches and 2250 RPM (P172).
- (3) Mixture: Full rich (unless engine is rough).
- (4) Cowl Flaps - "OPEN" (P172).

MAXIMUM PERFORMANCE CLIMB.

- (1) Airspeed - 80 MPH at sea level to 77 MPH at 10,000 feet (172),
85 MPH at sea level to 83 MPH at 10,000 feet (P172).
- (2) Power: Full throttle (172),
Full throttle and 2400 RPM (P172).
- (3) Mixture - Full rich unless engine is rough.
- (4) Cowl Flaps - "OPEN" (P172).

CRUISING.

- (1) Power: 2200 to 2700 RPM (172),
2000 to 2250 RPM and 15-23 inches Hg. (P172).
- (2) Trim Tab - Adjust.
- (3) Mixture - Lean.

LET-DOWN.

- (1) Mixture - Rich.
- (2) Power - As desired.
- (3) Carburetor Heat - As required to prevent carburetor icing.

BEFORE LANDING.

- (1) Fuel Selector - "BOTH ON."
- (2) Mixture - Rich.
- (3) Propeller - High RPM (full in). (P172)
- (4) Airspeed - 70 - 80 MPH (flaps up).

Operating Check List

- (5) Carburetor Heat - Apply before closing throttle.
- (6) Cowl Flaps - "CLOSED." (P172)
- (7) Flaps - As desired (below 100 MPH).
- (8) Airspeed - 65 to 75 MPH (flaps down).
- (9) Trim Tab - Adjust.

NORMAL LANDING.

- (1) Touchdown - Main wheels first.
- (2) Landing Roll - Lower nosewheel gently.
- (3) Braking - Minimum required.
- (4) Cowl Flaps - Open at end of ground roll. (P172)

AFTER LANDING.

- (1) Flaps - Up.
- (2) Brakes - Set (at parking area).
- (3) Mixture - Full lean.
- (4) Ignition Switch and Master Switch - "OFF."

section 3

operating details



The following paragraphs cover in somewhat greater detail the items entered as a Check List in Section II. Every item in the list is not discussed here. Only those items on the Check List that required further explanation will be found in this section.

PREFLIGHT CHECK.

The exterior inspection described in Section II is recommended for the first flight of the day. Inspection procedures for subsequent flights normally are limited to brief checks of the tail surface hinges, fuel and oil quantity, and security of fuel and oil filler caps. If the airplane has been subjected to long-term storage, recent major maintenance, or operation from marginal airports, a more extensive exterior inspection is recommended.

After major maintenance has been performed, the flight and trim tab controls should be double-checked for free and correct movement.

The security of all inspection plates on the airplane should be checked following periodic inspections. If the airplane has been waxed and polished, it is a good practice to check the external static pressure source hole for stoppage.

If the airplane has been exposed to much ground handling in a crowded hangar, it should be checked for

dents and scratches on wings, fuselage, and tail surfaces, as well as damage to navigation and landing lights, and radio antennas. Outside storage for long periods may result in water and obstructions in the airspeed system lines, condensation in fuel tanks, and dust and dirt on the intake air filters and engine cooling fins.

Operation from a gravel or cinder field will require extra attention to propeller tips and abrasion on leading edges of the horizontal tail.

Airplanes that are operated from rough fields, especially at high altitudes, are subjected to abnormal landing gear abuse. A frequent check of all components of the landing gear shock strut, tires, and brakes is important.

If night flying is anticipated, all exterior and interior lights should be checked for proper illumination. Cold weather flights involve a careful check of other specific areas that will be discussed in a separate paragraph.

STARTING ENGINE.

Ordinarily the engine starts easily with one or two strokes of the primer in warm temperatures to six strokes in cold weather, with the throttle open approximately 1/8 inch. In extremely cold temperatures, it may be necessary to continue priming while cranking.

Weak intermittent explosions followed by puffs of black smoke from the exhaust stack indicates over-priming or flooding. Excess fuel can be cleaned from the combustion chambers by the following procedure: Set the mixture control full lean and the throttle full open; then crank the engine through several revolutions with the starter. Repeat the starting procedure without any additional priming.

If the engine is underprimed (most likely in cold weather with a cold engine) it will not fire at all, and additional priming will be necessary. As soon as the cylinders begin to fire, open the throttle slightly to keep it running.

After starting, if the oil gage does not begin to show pressure within 30 seconds in the summertime and about twice that long in very cold weather, stop engine and investigate. Lack of oil pressure can cause serious engine damage. After starting, avoid the use of carburetor heat unless icing conditions prevail.

The use of an external power source is recommended for starting in cold weather. Before connecting a generator type external power source it is important that the master switch

be turned on. This will enable the battery to absorb transient voltages which otherwise might damage the transistors in the audio amplifier. When using a battery type cart the master switch should be turned off.

TAXIING.

Release the parking brake before taxiing and use the minimum amount of power necessary to start the airplane moving. During taxi, and especially when taxiing downwind, the RPM should be held down to prevent excessive taxi speeds.

Taxiing should be done at a speed slow enough to make the use of brakes almost entirely unnecessary. Using the brakes as sparingly as possible will prevent undue wear and strain on the tires, brakes, and landing gear.

Normal steering is accomplished by applying pressure to the rudder pedal in the direction the airplane is to be turned. For smaller radius turns, at slow speed, the brakes may be used on the inside wheel. At slow taxi speed, this airplane may be pivoted about the outboard strut fitting without sliding the tires.

When taxiing in crosswinds it is important that speed and use of brakes be held to a minimum and that all controls be utilized (see taxiing diagram, figure 3-1) to maintain directional control and balance.

NOTE

Caution should be used when taxiing over rough fields to avoid ex-

TAXIING DIAGRAM

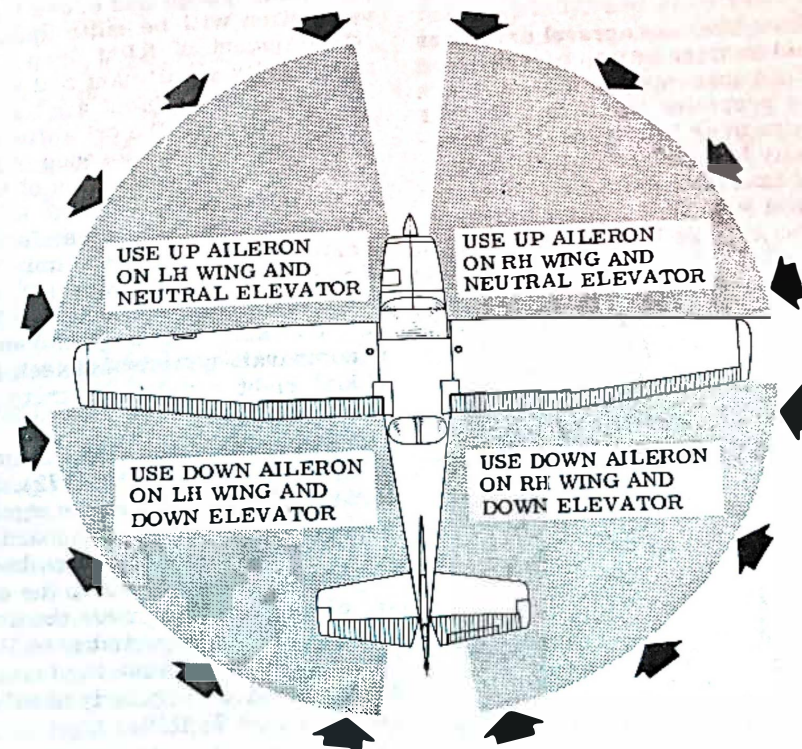

CODE
WIND DIRECTION →

NOTE

Strong quartering tail winds require caution. Avoid sudden bursts of the throttle and sharp braking when the airplane is in this attitude. Use the steerable nose wheel and rudder to maintain direction.

Figure 3-1.

cessive loads on the nosewheel. Rough use of brakes and power also add to nosewheel load. A good rule of thumb: "Use minimum speed, power, and brakes."

Taxiing over loose gravel or cinders should be done at low engine speed to avoid abrasion and stone damage to the propeller tips. Full throttle run-ups over loose gravel are especially harmful to propeller tips. When take-offs must be made over a gravel surface, it is very important that the throttle be advanced slowly. This allows the airplane to start rolling before high RPM is developed, and the gravel will be blown back of the propeller rather than pulled into it. When unavoidable small dents appear in the propeller blades, they should be immediately corrected as described in Section V under propeller care.

BEFORE TAKE-OFF.

WARM-UP.

Most of the warm-up will have been conducted during taxi, and additional warm-up before take-off should be restricted to the checks outlined in Section II. Since the engine is closely cowed for efficient in-flight engine cooling, precautions should be taken to avoid overheating on the ground.

MAGNETO CHECK.

An operational check of the magneto ignition system is important before take-off. An RPM drop on single ignition is a natural characteristic of dual ignition design in modern en-

gines. The purpose of the magneto check is to determine that all cylinders are firing. If all cylinders are not firing, the engine will run extremely rough and cause for investigation will be quite apparent.

The amount of RPM drop is not necessarily significant and will be influenced by ambient air temperature, humidity, airport altitude and other factors. An absence of RPM drop may be an indication of faulty grounding of one side of the ignition system or should be cause for suspicion that the magneto timing has been "bumped-up" and is set in advance of the setting specified. Magneto checks should be performed on a comparative basis between individual right and left magneto performance.

The magneto check should be made as follows: 1600 RPM (172), 1500 RPM (P172). Move the ignition switch first to "R" position, and note RPM. Next move the switch back to "BOTH" position to clear the other set of plugs. Then move the switch to the "L" position and note RPM. The difference between the two magnetos operated singularly should not be more than 75 RPM.

HIGH RPM MAGNETO CHECKS.

If there is a doubt concerning the operation of the ignition system, RPM checks at higher engine speeds will usually confirm whether a deficiency exists. If a full throttle run-up is necessary the engine should run smoothly and turn approximately 2230 to 2330 RPM (172), 2350 RPM (P172), with the carburetor heat off.

LAST MINUTE CHECK

A simple last-minute recheck of important items should include a glance to see that the mixture, propeller (P172), and carburetor heat knobs are full in, all flight controls have free and correct movement, and the fuel selector is set to "BOTH ON."

TAKE-OFF.

POWER CHECK.

Since the use of full throttle is not recommended in the static run-up, it is important to check full-throttle engine operation early in the take-off run. Any signs of rough engine operation or sluggish engine acceleration is good cause for discontinuing the take-off. If this occurs, you are justified in making a thorough full-throttle static run-up before another take-off is attempted.

FLAP SETTINGS (172).

Normal and obstacle clearance take-offs are performed with flaps up. The use of 10° flaps will shorten the ground run approximately 10%, but this advantage is lost in the climb to a 50-foot obstacle. Therefore the use of 10° flap is reserved for minimum ground runs or for take-off from soft or rough fields with no obstacles ahead.

If 10° of flaps are used in ground runs, it is preferable to leave them extended rather than retract them in the climb to the obstacle. The exception to this rule would be in a high altitude take-off in hot weather

Engine run-ups should not be performed over loose gravel or cinders because of possible damage or abrasion to propeller tips.

OIL PRESSURE.

If the engine accelerates smoothly and the oil pressure remains steady at some value between 30 and 60 lbs/sq. in. the engine is warm enough for take-off.

IDLE CHECK.

The engine should be checked for idling at approximately 500 RPM for the (172) and between 375 and 450 RPM for the (P172). However, prolonged idling should be done above 600 RPM for better engine lubrication.

INSTRUMENT & NIGHT FLIGHTS.

If instrument or night flights are contemplated, a careful check should be made of vacuum pump operation. A suction of 4.5 inches of mercury is desirable for gyro instruments. However, a range of 3.75 to 5.0 inches of mercury is considered acceptable.

On aircraft equipped with an optional pictorial gyro horizon, two lights are provided for suction checks. When neither light is on the suction pressure is acceptable. A vacuum lights test switch is provided to test the lights electrically.

The condition of the generator is also important for night flight, since satisfactory operation of all radio, lights, and electrical instruments is essential to instrument or night flight. The generator is checked by noting that the warning light is out with engine speeds above approximately 1000 RPM.

where climb would be marginal with flaps 10° (1st notch).

Flap deflections of 30° (3rd notch) and 40° (4th notch) are not recommended at any time for take-off.

FLAP SETTINGS (P172).

Normal take-offs are performed with flaps retracted. Minimum run, obstacle clearance, and soft or rough field take-offs are performed with flap settings of 10°. With flaps deflected 10° ground run is reduced slightly, total distance to clear a 50-foot obstacle is reduced approximately 10%, and take-off speed is approximately 5 MPH slower.

Flap deflections of 30° and 40° are not recommended at any time for take-off.

PERFORMANCE CHARTS.

Consult the take-off chart (figure 6-3) for take-off distances under various gross weight, altitude, and headwind conditions.

CROSSWIND TAKE-OFFS.

Take-offs into strong crosswinds normally are performed with the minimum flap setting necessary for the field length, to minimize the drift angle immediately after take-off. The airplane is accelerated to a speed slightly higher than normal, then pulled off abruptly to prevent possible settling back to the runway while drifting. When clear of the ground, make a coordinated turn into the wind to correct for drift.

CLIMB.

For detailed data, refer to the Climb Performance Charts in Section VI.

CLIMB SPEEDS (172).

Normal climbs are performed at 80 to 90 MPH with flaps up and full throttle for best engine cooling. The mixture should be full rich unless the engine is rough due to too rich a mixture. The best rate of climb speeds range from 80 MPH at sea level to 77 MPH at 10,000 feet. If an obstacle dictates the use of a steep climb angle, the best angle-of-climb speed should be used with flaps up and full throttle. These speeds vary from 65 MPH at sea level to 71 MPH at 10,000 feet.

NOTE

Steep climbs at these low speeds should be of short duration to improve engine cooling.

CLIMB SPEEDS (P172).

Normal climbs are conducted at 90 to 100 MPH with flaps up, 2250 RPM and 23 inches Hg., for best engine cooling. The mixture should be full rich unless the engine is rough due to too rich a mixture. The best rate-of-climb speeds range from 85 MPH at sea level to 83 MPH at 10,000 feet. If an obstacle dictates the use of a steep climb angle, the best angle-of-climb should be used with flaps up and full throttle. These speeds vary from 55 MPH at sea level to 71 MPH at 10,000 feet.

NOTE

Steep climbs at these low speeds should be of short duration to improve engine cooling.

CRUISE.

Cruising charts are presented in Section VI. It can be seen that the speeds for maximum range are much lower than normal cruise speed. Since the main advantage of the airplane over ground transportation is speed, one should utilize the highest cruising speeds obtainable. However, if a destination is slightly out of reach in one hop at normal cruising speed, it would save time and money to make the trip non-stop at some lower speed. An inspection of these cruising charts shows the longer ranges obtainable at lower cruising speeds.

Allowances for fuel reserve, headwinds, take-offs and climb or variations in mixture leaning technique should be made and are in addition to those shown in the charts.

EFFECT OF ALTITUDE (172).

Normal cruising is done at 65% to 75% power. Cruising power of approximately 75% is obtained at engine speeds between 2450 RPM and 2625 RPM depending on the altitude. To maintain 75% power, progressively higher throttle openings are required as the altitude is increased until, at 7000 feet, full throttle is reached.

Cruising can be done most effi-

ciently at high altitudes because of lower air density and therefore lower airplane drag. This is illustrated in the following table which shows performance at 75% power at various altitudes.

ALTITUDE	RPM	TRUE AIR-SPEED	RANGE
Sea Level	2450	123	520
5000 ft	2560	128	540
7000 ft	Full Throttle	130	550

All figures are based on, lean mixture, 36 gallons of fuel (no reserve), zero wind, standard atmospheric conditions, and 2300 pounds gross weight.

EFFECT OF ALTITUDE (P172).

Normal cruising is done at 65% to 75% power. Cruising power of approximately 75% is obtained with 23 inches of manifold pressure and 2250 RPM. Various percent powers can be obtained with an infinite number of combinations of manifold pressures, engine speeds, altitudes, and outside air temperatures. However, at full throttle, a constant engine speed and a standard air temperature, a specific power may be obtained at only one altitude. For example, with the airplane at full throttle and 2250 RPM, the following are the speed and range figures for various powers and optimum altitudes.

The Cruise and Performance Charts in Section VI as well as the following table, are based on flight test with

lean mixture and 41.5 gallons of fuel for cruising.

% BHP	TRUE ALTITUDE	AIRSPEED	RANGE
75	6,800	140	545
70	8,900	137	570
65	10,900	134	590

This table shows that cruising can be done most efficiently at higher altitudes because very nearly the same cruising speed can be maintained at much less power. This means savings in fuel consumption and engine wear.

The cowl flaps should be adjusted to maintain the cylinder head temperature near the middle of the normal operating (green arc) range to assure prolonged engine life.

STALLS.

The stalling speeds are shown in Section VI for aft c. g., normal category, full gross weight conditions. They are presented as calibrated airspeeds because indicated airspeeds are inaccurate near the stall. The horn stall warning indicator produces a steady signal 5 to 10 MPH before the actual stall is reached and remains on until the airplane flight attitude is changed. Fast landings will not produce a signal.

The stall characteristics are conventional for the flaps up and flaps down condition. Slight elevator buffeting may occur just before the stall with flaps down.

LANDING.

Normal landings are made power off with any flap setting. Slips are prohibited in full flap approaches because of a downward pitch encountered under certain combinations of airspeed and sideslip angle.

Approach glides are normally made at 70 to 80 MPH with flaps up, or 65 to 75 with flaps down, depending upon the turbulence of the air.

Landings are usually made on the main landing wheels to reduce the landing speed and the subsequent need for braking in the landing roll. The nosewheel is lowered gently to the runway after speed has diminished to avoid unnecessary nose gear strain. This procedure is especially important in rough field landings.

Excessive braking in the landing roll is not recommended because of the probability of skidding the main wheels with the resulting loss of braking effectiveness and damage to the tires.

SHORT FIELD LANDINGS.

For a short field landing, make a power-off approach at approximately 67 MPH with flaps 40° (fourth notch) and land on the main wheels first. Immediately after touchdown, lower the nose gear to the ground and apply heavy braking as required. Raising the flaps after landing will provide more efficient braking.

CROSSWIND LANDINGS.

When landing in a strong crosswind, use the minimum flap setting required for the field length. Use

a wing low, crab, or a combination method of drift correction and land in a nearly level attitude. Hold a straight course with the steerable nosewheel and occasional braking if necessary.

COLD WEATHER OPERATION.

Prior to starting on cold mornings, it is advisable to pull the propeller through several times by hand to "break loose" or "limber" the oil, thus conserving battery energy. In extremely cold (0°F and lower) weather the use of an external preheater for both the engine and battery is recommended whenever possible to reduce wear and abuse to the engine and the electrical system. Cold weather starting procedures are as follows:

With Pre-heat:

- (1) Clear propeller.
- (2) Pull master switch "ON."
- (3) With magneto switch "OFF" and throttle closed, prime the engine four to ten strokes as the engine is being turned over.

NOTE

After priming, push primer all the way in and turn to locked position to avoid possibility of engine drawing fuel through the primer.

- (4) Turn magneto switch to "BOTH."
- (5) Open throttle 1/4" and engage starter.

Without Preheat:

- (1) Prime the engine 8 to 10 strokes

while the propeller is being turned by hand.

- (2) Clear propeller.
- (3) Pull master switch "ON."
- (4) Turn magneto switch to "BOTH."
- (5) Open throttle 1/4".
- (6) Pull carburetor air heat knob full on.
- (7) Engage starter and continue to prime engine until it is running smoothly.
- (8) Keep carburetor heat on until engine has warmed up.

NOTE

If the engine does not start the first time it is probable that the spark plugs have been frosted over. Preheat must be used before another start is attempted.

During cold weather operations, no indication will be apparent on the oil temperature gage prior to take-off if outside air temperatures are very cold. After a suitable warm-up period (2 to 5 minutes at 1000 RPM), accelerate the engine several times to higher engine RPM. If the engine accelerates smoothly and the oil pressure remains normal and steady, the airplane is ready for take-off.

When operating in sub-zero temperature, avoid using partial carburetor heat. Partial heat may increase the carburetor air temperature to the 32° to 80°F range, where icing is critical under certain atmospheric conditions.

For operation at temperatures consistently below freezing, a winterization kit is available at your Cessna Dealer for a nominal charge.

MODIFIED FUEL MANAGEMENT PROCEDURES

With a combination of highly volatile fuel, high fuel temperature, high operating altitude, and low fuel flow rate in the tank outlet lines, there is a remote possibility of accumulating fuel vapor and encountering power irregularities on some airplanes. To minimize this possibility, the following operating procedures are recommended:

- (1) Take-off and climb to cruise altitude on "both" tanks.
(This is consistent with current recommendations.)
- (2) When reaching cruise altitude above 5000 feet MSL, promptly switch the fuel selector valve from "both" tanks to either the "right" or "left" tank.
- (3) During cruise, use "left" and "right" tank as required.
- (4) Select "both" tanks for landing as currently recommended.

POWER RECOVERY TECHNIQUES

In the remote event that vapor is present in sufficient amounts to cause a power irregularity, the following power recovery techniques should be followed:

OPERATION ON A SINGLE TANK

Should power irregularities occur when operating on a single tank, power can be restored immediately by switching to the opposite tank. In addition, the vapor accumulation in the tank on which the power irregularity occurred will rapidly dissipate itself such that that tank will also be available for normal operation after it has been unused for approximately one (1) minute.

OPERATION ON BOTH TANKS

Should power irregularities occur with the fuel selector on both tanks, the following steps are to be taken to restore power:

- (1) Switch to a single tank for a period of 60 seconds.
- (2) Then switch to the opposite tank and power will be restored.



OPERATIONS AUTHORIZED.

Your Cessna with standard equipment as certificated under FAA Type Certificate No. 3A12 (172), No. 3A17 (P172), is approved for day and night operation under VFR.

Additional optional equipment is available to increase its utility and to make it authorized for use under IFR day and night. An owner of a properly-equipped Cessna is eligible to obtain approval for its operation on single engine scheduled airline service on VFR.

MANEUVERS - NORMAL CATEGORY.

The airplane exceeds the requirements of the Civil Air Regulations, Part 3, set forth by the United States Government for airworthiness. Spins and aerobatic maneuvers are not permitted in normal category airplanes in compliance with these regulations. In connection with the foregoing, the following gross weights and flight load factors apply:

Gross Weight	2300 lbs. (172) - 2500 lbs. (P172).
Flight Load Factor *Flaps Up	+3.8 -1.5 2
Flight Load Factor *Flaps Down	+3.5

*The design load factors are 150% of the above and in all cases the structure meets or exceeds design loads.

Your airplane must be operated in accordance with all FAA approved markings, placards and check lists in the airplane. If there is any information in this section which contradicts the FAA approved markings, placards and check lists, it is to be disregarded.

MANEUVERS - UTILITY CATEGORY (172) .

This airplane is not designed for purely aerobatic flight. However, in the acquisition of various certificates such as commercial pilot, instrument pilot and flight instructor, certain maneuvers are required by the FAA. All of these maneuvers are permitted in this airplane when operated in the utility category. In connection with the utility category, the follow-

Operating Limitations

ing gross weight and flight load factors apply, with recommended entry speeds for maneuvers as shown.

Maximum Design Weight	2000 lbs.
Flight Maneuvering Load Factor, Flaps Up	+4.4 -1.76
Flight Maneuvering Load Factor, Flaps Down	+3.5

No acrobatic maneuvers are approved except those listed below:

Maneuver	Entry Speed
Chandelles	122 mph (106 knots)
Lazy Eights	122 mph (106 knots)
Steep Turns	122 mph (106 knots)
Spins	Slow Deceleration
Stalls (Except Whip Stalls)	Slow Deceleration

The baggage compartment and rear seat must not be occupied.

Aerobatics that may impose high inverted loads should not be attempted. The important thing to bear in mind in flight maneuvers is that your Cessna is clean in aerodynamic design and will build up speed quickly with the nose down. Proper speed control is an essential requirement for execution of any maneuver and care should always be exercised to avoid excessive speed which in turn can impose excessive loads. In the execution of all maneuvers avoid abrupt use of controls.

AIRSPED LIMITATIONS.

	(172)	(P172)
RED LINE	174 mph	182 mph
YELLOW ARC	140-174 mph	145-182 mph
GREEN ARC	59-140 mph	64-145 mph
WHITE ARC	52-100 mph	56-100 mph
MANEUVERING SPEED*	122 mph	127 mph

*The maximum speed at which you can use abrupt control travel without exceeding the design load factor.

NOTE

- RED LINE . . . Maximum Speed (Glide or dive, smooth air).
- YELLOW ARC . . . Caution Range (Level flight or climb).
- GREEN ARC . . . Normal Range (Level flight or climb).
- WHITE ARC . . . Flap Operating Range

Operating Limitations

ENGINE OPERATION LIMITATIONS.

Power and Speed:	(172)	(P172)
	145 bhp at 2700 rpm	175 bhp at 2400 rpm

ENGINE INSTRUMENT MARKINGS.

OIL TEMPERATURE GAGE.

Normal Operating Range	Green Arc
Maximum Allowable	Red Line

OIL PRESSURE GAGE.

Minimum Idling	10 psi (red line)
Normal Operating Range	30-60 psi (green arc)
Maximum	100 psi (red line)

FUEL QUANTITY INDICATORS.

EMPTY	E (red line)
	1.50 gallons unusable each tank (172).
	5.25 gallons unusable each tank (P172).

TACHOMETER.

	(172)	(P172)
Normal Operating Range:		
At sea level (inner green arc)	2200-2500	
At 5000 feet (middle green arc)	2200-2600	
At 10,000 feet (outer green arc)	2200-2700	
Green Arc		1950-2250
Maximum Allowable (Red line)	2700	2400

MANIFOLD PRESSURE GAGE. (P172)

Normal Operating Range	15-23 in. Hg. (green arc)
----------------------------------	---------------------------

WEIGHT AND BALANCE.

The information presented in this section will enable you to operate your Cessna within the prescribed weight and center of gravity limitations. In figuring your loading problems be certain that you use the Licensed Empty Weight of your particular airplane as shown on its Weight and Balance

Operating Limitations

Data Sheet. This sheet, plus an Equipment List, is included with each airplane as it leaves the factory. The FAA requires that any change in the original equipment, affecting the empty weight center of gravity, be recorded on a Repair and Alteration Form FAA-337.

READ BEFORE WORKING LOADING PROBLEM FOR YOUR AIRPLANE.

To figure the weight for your airplane in the same manner as the sample problem on page 4-5 or 4-6 proceed as follows:

- Step 1. Take the licensed Empty Weight and Moment/1000 from the Weight and Balance Data sheet carried in your airplane and write them down in two columns in the manner shown in the sample problem. These figures are non-variables and, unless your airplane or equipment is modified, these figures may be used every time you figure your weight and balance.
- Step 2. Write down the weight and moment/1000 for the oil in the proper columns. Use 8 qts at 15 lbs and a moment of -0.3 for the (172). Use 10 qts at 19 lbs and a moment of -0.4 for the (P172). Since you usually have a full load of oil for a trip you may also consider these figures as non-variable and use them every time.
- Step 3. Add the weight of yourself and the front passenger. Refer to the loading graph (on page 4-6) and find this weight at the left side of the graph, and then go across the graph horizontally to the right until you intersect the line identified as "PILOT AND FRONT PASSENGER." After intersecting the line drop down vertically to the bottom line and read the moment/1000 given on the scale. Now write down this weight and moment/1000 for you and the front passenger in the proper columns.
- Step 4. Proceed as you did in step 3, except use the line identified as "FUEL" and 6 lbs. per gallon for the amount of gasoline you are carrying, and read the moment/1000 from the loading graph. Write the weight and moment/1000 in the proper columns.
- Step 5. Proceed as you did in step 3, except use the line identified as "REAR PASSENGERS," and read the moment/1000 for the combined weight of the rear passengers being carried. Write the weight and moment/1000 in the proper columns.

Operating Limitations

- Step 6. Proceed as you did in step 3, except use the line identified as "BAGGAGE OR PASSENGER ON AUXILIARY SEAT," and read the moment/1000 for the number of pounds of baggage (or weight of passenger) being carried. Write the weight and moment/1000 in the proper columns.
- Step 7. Add the weight column. The total must be 2300 lbs or less for the (172) and 2500 lbs or less for the (P172), or you must lighten your aircraft load. Add the moment column (remember to subtract, rather than add, the oil moment because it is a minus quantity).
- Step 8. Refer to the Center of Gravity Moment Envelope. Locate the total weight on the scale on the left hand side of the graph and, from this point, follow a line horizontally to the right. Locate the total moment/1000 on the scale running across the bottom of the graph and, from this point, follow a line vertically up until you intersect the line running horizontally from your total weight. If the point where the two lines intersect is within the envelope, your airplane is loaded within approved limits. If the point of intersection falls outside the envelope, your load must be adjusted before flight.

172		Sample Airplane		Your Airplane	
SAMPLE LOADING PROBLEM		Weight (lbs)	Moment (lb - ins. /1000)	Weight ⋮	Moment ⋮
1. Licensed Empty Weight (Sample Airplane) ...		1324	48.2		
2. Oil - 8 Qts.*		15	-0.3	15	-0.3
3. Pilot & Front Passenger		340	12.2		
4. Fuel- (36 Gal at 6#/Gal) <i>34 gal</i>		<i>204</i>	10.4		
5. Rear Passengers		340	23.8		
6. Baggage (or Passenger on Auxiliary Seat)		65	6.2		
7. Total Aircraft Weight (Loaded)		2300	100.5		

8. Locate this point (2300 at 100.5) on the center of gravity envelope, and since this point falls within the envelope the loading is acceptable.

*Note: Normally full oil may be assumed for all flights.

aux. tank 18 gal. = 108 lbs,

PI72 SAMPLE LOADING PROBLEM			Sample Airplane		Your Airplane	
	Weight (lbs)	Moment (lb-ins. /1000)	Weight	Moment	Weight	Moment
1. Licensed Empty Weight (Sample Airplane) ...	1507	56.6				
2. Oil - 10 Qts.*	19	-0.4	19	-0.4		
3. Pilot & Front Passenger	340	12.0				
4. Fuel- (41.5 Gal at 6#/Gal)	249	9.5				
5. Rear Passengers	340	23.8				
6. Baggage (or Passenger on Auxiliary Seat)	45	4.3				
7. Total Aircraft Weight (Loaded).....	2500	108.5				

8. Locate this point [2500 at 108.5 on the center of gravity envelope, and since this point falls within the envelope the loading is acceptable.

*Note: Normally full oil may be assumed for all flights.

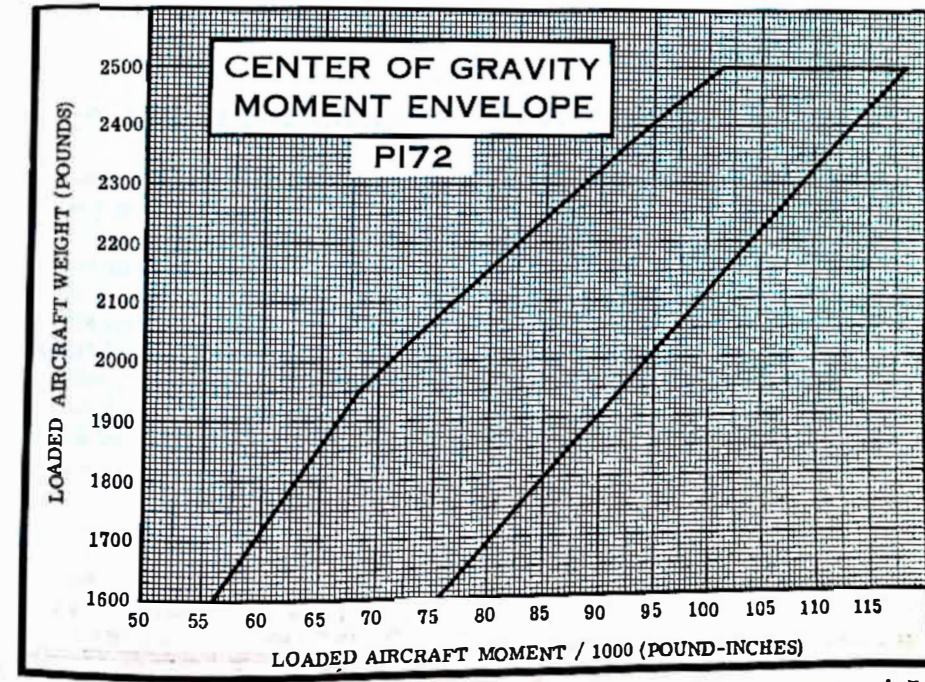
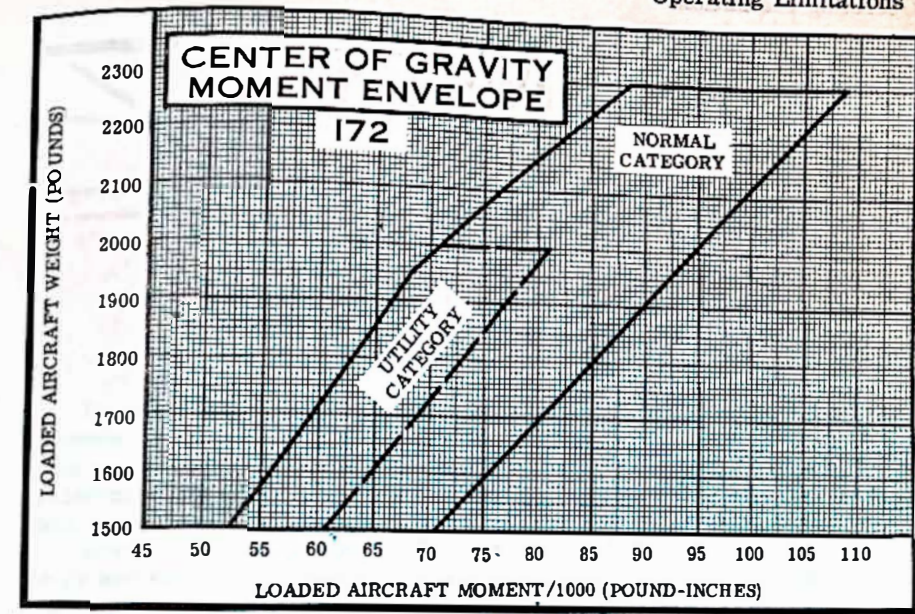
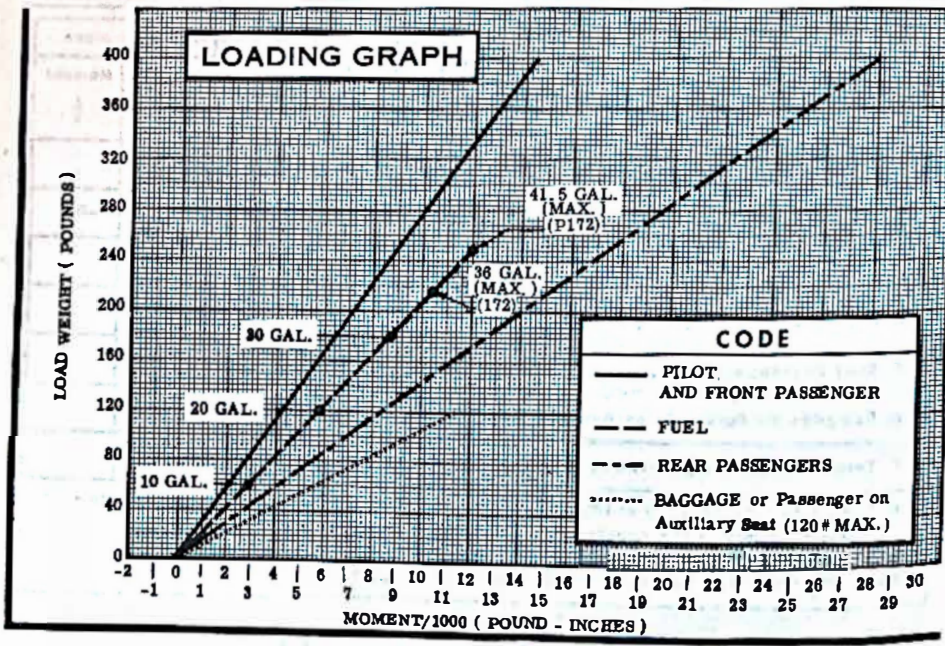

Notes



Care of the Airplane

If your airplane is to retain that new plane performance, stamina, and dependability, certain inspection and maintenance requirements must be followed. It is always wise to follow a planned schedule of lubrication and maintenance based on the climatic and flying conditions encountered in your locality..

Keep in touch with your Cessna Dealer and take advantage of his knowledge and experience. He knows your airplane and how to maintain it. He will remind you when lubrications and oil changes are necessary and about other seasonal and periodic services.

GROUND HANDLING.

The airplane is most easily and safely maneuvered by hand with the tow-bar attached to the nosewheel. When moving the airplane by hand, if no tow-bar is available, push down at the front spar of the stabilizer next to the fuselage to raise the nosewheel off the ground. When the nosewheel is held clear of the ground the airplane can be turned readily in any direction by pivoting it about the main gear. Do not push down on the empennage by the tip of the elevator nor shove sidewise on the upper portion of the fin. When moving the airplane forward or backwards, push at the wing strut root fitting or at the main gear strut.

MOORING YOUR AIRPLANE.

Proper tie-down procedure is your best precaution against damage to your parked airplane by gusty or strong winds. To tie down your airplane securely, proceed as follows:

- (1) Tie sufficiently strong ropes or chains (700 pounds tensile strength) to the wing tie-down fittings located at the upper end of each wing strut.
- (2) Secure the opposite ends of these ropes or chains to tie-down rings suitably anchored in the ground.
- (3) Tie a rope or chain through the nose gear tie-down ring and secure the opposite end to a tie-down ring in the ground.
- (4) Securely tie the middle of a length of rope to the ring at the

tail. Pull each end of the rope away at 45° angle and secure to tie-down rings positioned on each side of the tail.

(5) Install surface control locks between the flap and aileron of each wing.

(6) Install the controls lock in the pilot's control wheel shaft.

(7) Install a surface control lock over the fin and rudder.

STORAGE.

The all-metal construction of your Cessna makes outside storage of it practical. However, inside storage of the airplane will increase its life just as inside storage does for your car. If your airplane must remain inactive for a time, cleanliness is probably the most important consideration, whether it is stored inside or outside. A small investment in cleanliness will repay you many times, not only in keeping your airplane looking like new but in keeping it new. Later paragraphs in this section cover the subject in greater detail.

Do not neglect the engine when storing the airplane. Turn the propeller over by hand or have it turned over every few days to keep the engine bearings, cylinder walls, and internal parts lubricated. Full fuel tanks will help prevent condensation and will increase fuel tank life.

Regular use helps keep airplanes in good condition. An airplane left standing idle for any great length of time is likely to deteriorate more rapidly than if it is flown regularly, and it should be carefully checked

over before being put back into service.

WINDSHIELD - WINDOWS.

The windshield is a single piece, full-floating, "free-blown" unit of "Longlife" plastic. To clean the plastic, wash with plenty of soap and water, using the palm of the hand to feel and dislodge any caked dirt. A soft cloth, chamois or sponge may be used, but only as a means of carrying water to the plastic. Rinse thoroughly, then dry with a clean, moist chamois. Rubbing with a dry cloth builds up an electrostatic charge so that it attracts dust particles from the air. Wiping with a moist chamois will remove both the dust and this charge.

Remove oil and grease with a cloth moistened with kerosene. Never use gasoline, benzene, alcohol, acetone, carbon tetrachloride, fire extinguisher or anti-ice fluid, lacquer thinner or glass cleaner. These materials will soften the plastic and may cause it to craze.

After removing dirt and grease, if the surface is not seriously scratched it should be waxed with a good grade of commercial wax. The wax will fill in minor scratches and help prevent further scratching. Apply a thin, even coat of wax and bring it to a high polish by rubbing lightly with a clean, dry, soft flannel cloth. Do not use a power buffer; the heat generated by the buffing pad will soften the plastic.

Do not use a canvas cover on the windshield unless freezing rain or sleet is anticipated. Canvas covers may scratch the plastic.

ALUMINUM SURFACES.

The clad aluminum surfaces of your Cessna require only a minimum of care to keep them bright and clean. The airplane may be washed with clear water to remove dirt; oil and grease may be removed with gasoline, naphtha, carbon tetrachloride or other non-alkaline solvents. Dulled aluminum surfaces may be cleaned effectively with an aircraft aluminum polish.

After cleaning, and periodically thereafter, waxing with a good automotive wax will preserve the bright appearance and retard corrosion. Regular waxing is especially recommended for airplanes operated in salt water areas as a protection against corrosion.

PAINTED SURFACES.

The painted exterior surfaces of your new Cessna have been finished with high grade materials selected for their toughness, elasticity, and excellent adhesion. With a minimum of care, they will retain their original beauty for many years.

As with any paint applied to a metal surface, the desired qualities of the paint develop slowly throughout an initial curing period which may be as long as 90 days after the finish is applied. During this curing period some precautions should be taken to avoid damaging the finish or interfering with the curing process. The finish should be cleaned only by washing with clean water and mild soap, followed by a rinse with water and drying with cloths or a chamois.

Do not use polish or wax, which would exclude air from the surface, during this 90-day curing period. Do not rub or buff the finish and avoid flying through rain, hail or sleet.

Once the finish has cured completely, it may be waxed with a good automotive wax. A heavier coating of wax on the leading edges of the wings and tail and on the nose cap and propeller spinner will help reduce the abrasion encountered in these areas.

Fluids containing dyes, such as fuel and hydraulic oil, accidentally spilled on the painted surface, should be flushed away at once to avoid a permanent stain. Battery electrolyte must be flushed off at once, and the area neutralized with an alkali such as baking soda solution, followed by a thorough rinse with clear water.

An automotive paint cleaner may be used to clean the painted surfaces. Always wash and wax your airplane in a shaded area.

PROPELLER CARE.

Preflight inspection of propeller blades for nicks, and wiping them occasionally with an oily cloth to clean off grass and bug stains will assure long, trouble-free service. It is vital that small nicks on the propeller, particularly near the tips and on the leading edges, are dressed out as soon as possible since these nicks produce stress concentrations, and if ignored, may result in cracks. Never use an alkaline cleaner on the blades; remove grease and dirt with carbon tetrachloride or Stoddard solvent.

Your Cessna Dealer should be consulted about other repair and maintenance work. Civil Air Regulations require that all maintenance except dressing small blade nicks, cleaning, and minor repairs to the spinner be done by an FAA authorized propeller repair station.

INTERIOR CARE.

To remove dust and loose dirt from the upholstery and carpet, clean the interior regularly with a vacuum cleaner.

Blot up any spilled liquid promptly, with cleansing tissue or rags. Don't pat the spot - press the blotting material firmly and hold it for several seconds. Continue blotting until no more liquid is taken up. Scrape off sticky materials with a dull knife, then spot-clean the area.

Oily spots may be cleaned with household spot removers, used sparingly. Before using any solvent, read the instructions on the container and test it on an obscure place on the fabric to be cleaned. Never saturate the fabric with a volatile solvent; it may damage the padding and backing materials.

Soiled upholstery and carpet may be cleaned with a foam-type detergent, used according to the manufacturer's instructions. Keep the foam as dry as possible and remove it with a vacuum cleaner, to minimize wetting the fabric.

The plastic trim, headliner, instrument panel and control knobs need only be wiped off with a damp cloth. Oil and grease on the control wheel and control knobs can be removed

with a cloth moistened with kerosene. Volatile solvents, such as mentioned in paragraphs on care of the windshield, must never be used since they soften and craze the plastic.

INSPECTION SERVICE AND INSPECTION PERIODS.

With your airplane you will receive an Owner's Service Policy. This policy has coupons attached to it which entitle you to a no-charge initial inspection and a no-charge 100 hour inspection. If you take delivery from your Dealer, he will perform the initial inspection before delivery of the airplane to you. If you pick up the airplane at the factory, plan to take your airplane to your Dealer reasonably soon after you take delivery on it. This will permit him to check it over and to make any other minor adjustments that may appear necessary. Also plan an inspection by your Dealer at 100 hours or 90 days, whichever comes first. This inspection also is performed by your Dealer for you at no charge. While these important inspections will be performed for you by any Cessna Dealer, in most cases you will prefer to have the Dealer from whom you purchase the airplane accomplish this work for you.

Civil Air Regulations require all airplanes to have a periodic (annual) inspection as required by the administrator, made by a person designated by the administrator, and in addition, 100 hour periodic inspections made by an "appropriately rated mechanic" if the airplane is flown

for hire. The Cessna Aircraft Company recommends the 100 hour periodic inspection for your airplane. The procedure for this 100 hour inspection has been carefully worked out by the factory and is followed by the Cessna Dealer organization. The complete familiarity of the Cessna Dealer organization with Cessna equipment and with Cessna procedures provides the highest type of service possible at lower cost.

Time studies of the 100 hour inspection at the factory and in the field have developed a standard flat rate charge for this inspection at any Cessna Dealer. Points which the inspection reveals require modification or repairs will be brought to your attention by the Dealer and quotations or charges will be made accordingly. The inspection charge does not include the oil required for the oil change.

Every effort is made to attract the best mechanics in each community to Cessna service facilities. Many Dealers' mechanics have attended Cessna Aircraft Company schools and have received specialized instruction in maintenance and care of Cessna airplanes. Cessna service instruction activity in the form of service bulletins and letters is constantly being carried on so that when you have your Cessna inspected and serviced by Cessna Dealers' mechanics, the work will be complete and done in accordance with the latest approved methods.

Cessna Dealers maintain stocks of genuine Cessna parts and service facilities consistent with the demand. Your Cessna Dealer will be glad

to give you current price quotations on all parts that you might need and advise you on the practicability of parts replacement versus repairs that from time to time might be necessary.

AIRPLANE FILE.

There are miscellaneous data, information and licenses that are a part of the airplane file. The following is a check list for that file. In addition, a periodic check should be made of the latest Civil Air Regulations to insure that all data requirements are met.

- A. To be displayed in the airplane at all times:
 - (1) Aircraft Airworthiness Certificate (Form FAA 1362).
 - (2) Aircraft Registration Certificate (Form FAA 500A).
- B. To be carried in the airplane at all times:
 - (1) Airplane Radio Station License (if transmitter installed).
 - (2) Weight and Balance Report or latest copy of the Repair and Alteration Form (Form FAA 337).
 - (3) Airplane Equipment List.
 - (4) Airplane Log Book.
 - (5) Engine Log Book.
- C. To be maintained but not necessarily carried in the airplane at all times:
 - (1) A form containing the following information: Model, Registration Number, Factory Serial Number, Date of Manufacture, Engine Number, and Key Numbers (duplicate keys are available through your Cessna Dealer).

Most of the items listed are required by the United States Civil Air Regulations. Since the regulations of other nations may require

other information, owners of exported airplanes should check with their own aviation officials to determine their individual requirements.

LUBRICATION AND SERVICING.

Specific lubrication and servicing information is presented in figure 5-1. In addition, all pulleys, the trim tab actuator rod, bellcrank clevis bolts, flap handle, brake pedal pivots, rudder pedal crossbars, shimmy dampener pivots, door hinges and latches, Bowden controls, throttle, propeller, and cowl flaps control rod ends, and the control wheel shaft universal (if unsealed), should be lubricated with SAE 20 engine oil every 1,000 hours or oftener as required.

Generally, roller chains (aileron, tab wheel, tab actuator) and control cables collect dust, sand and grit if they are greased or oiled. Except under seacoast conditions, chains and cables should be merely wiped clean occasionally with a dry cloth.

DEALER FOLLOW-UP SYSTEM.

Your Cessna Dealer has an owner follow-up system to notify you when he receives information that applies to your Cessna. In addition, if you wish, you may choose to receive similar notification directly from the Cessna Service Department. A subscription card is supplied in your airplane file for your use, should you choose to request this service. Your Cessna Dealer will be glad to supply you with details concerning these follow-up programs, and stands ready through his Service Department to supply you with fast, efficient, low cost service.

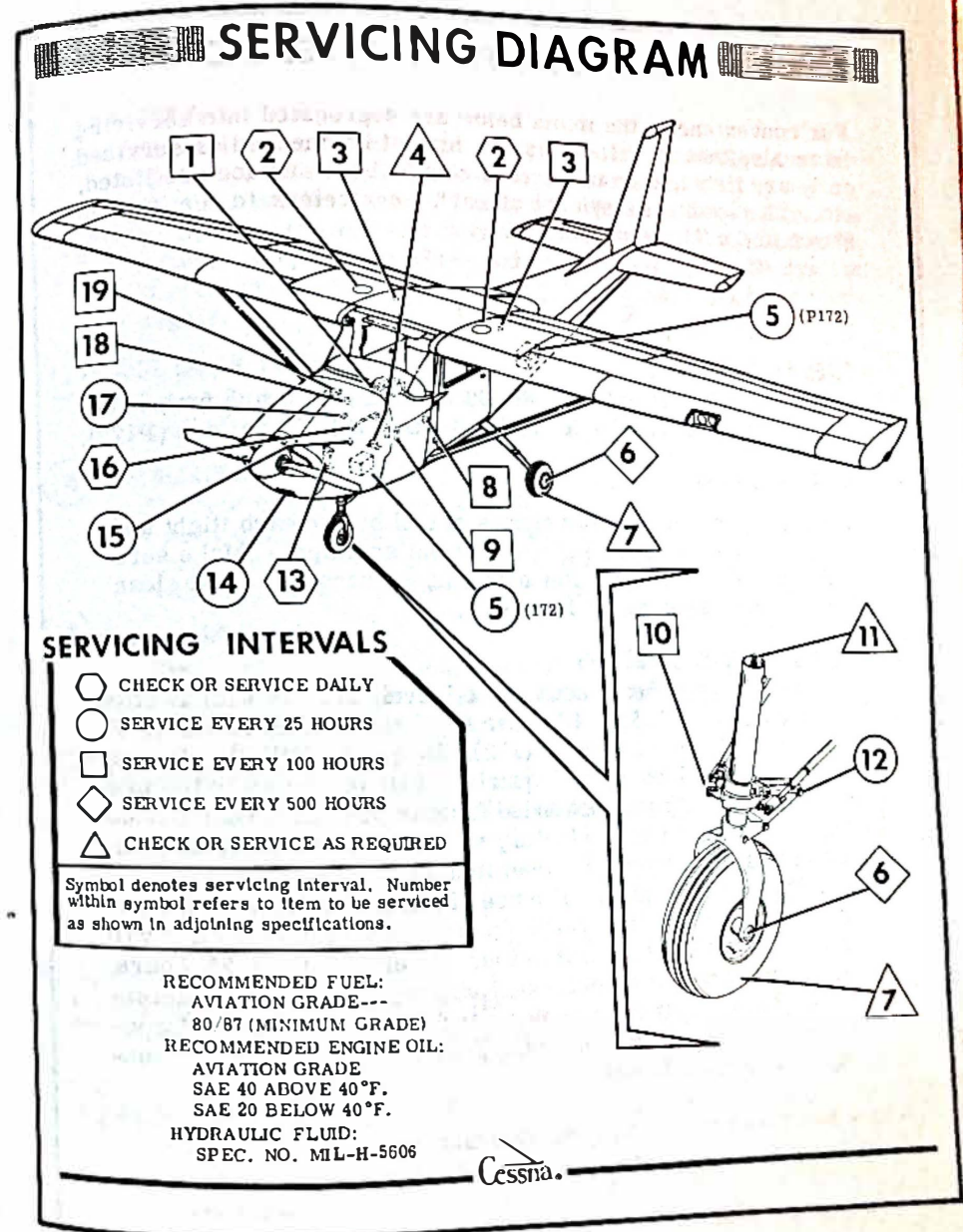

Figure 5-1 (Sheet 1 of 5).

SERVICING PROCEDURES

For convenience, the items below are segregated into servicing intervals; that is, all items which must be checked or serviced daily are listed, then items requiring 25 hour service are listed, etc. The numbered symbol at each item refers to the item as shown in the Servicing Diagram.

⬡ DAILY

② FUEL TANK FILLERS:

Service after each flight with 80/87 minimum grade fuel. The capacity of each tank is: 19.5 gallons (172), 26 gallons (P172).

⑬ FUEL STRAINER:

Drain approximately two ounces of fuel before each flight and after refueling to remove water and sediment. Make sure drain valve is closed after draining. Disassemble and clean bowl and screen every 100 hours.

⑯ OIL FILLER AND DIPSTICK:

When preflight check shows low oil level, service with aviation grade engine oil; SAE 40 above 40°F and SAE 20 below 40°F. Oil capacity is: 8 quarts (172), 10 quarts (P172). Do not operate with less than 6 quarts. Fill the sump to the prescribed capacity if an extended flight is planned. Your Cessna was delivered from the factory with straight mineral oil (non-detergent) and should be operated with straight mineral oil for the first 25 hours. The use of mineral oil during the 25-hour break-in period will help seat the piston rings and will result in less oil consumption. After the first 25 hours, either mineral oil or detergent oil may be used. If a detergent oil is used, it must conform to Continental Motors Corporation Specification MHS-24. Your Cessna Dealer can supply an approved brand.

○ 25 HOURS

⑤ BATTERY:

Check level of electrolyte every 25 hours (or at least every 30 days), oftener in hot weather. Maintain level by adding distilled water. DO NOT overfill. Immediately neutralize spilled electrolyte with baking soda solution, then flush with water. Keep battery clean and connections tight. Neutralize corrosion deposits with baking soda solution, then rinse thoroughly.

⑫ NOSE GEAR TORQUE LINKS:

Every 25 hours, lubricate through grease fittings with MIL-G-7711 or general purpose grease. Wipe off excess.

⑭ CARBURETOR AIR FILTER:

Service every 25 hours or oftener when operating in dusty conditions. Under extremely dusty conditions, daily maintenance of the filter is recommended. Service in accordance with instructions on the filter frame.

⑮ OIL SUMP DRAIN:

Every 25 hours, change engine oil. Drain oil by removing plug in sump. Remove lower cowling and provide protection for nose gear when draining.

⑰ ENGINE OIL SCREENS:

Remove and wash screen (located at rear of engine accessory section) with Stoddard solvent (Fed. Spec. P-S-661) whenever engine oil is changed.

□ 100 HOURS

① GYRO INSTRUMENT AIR FILTERS:

Replace every 100 hours and when erratic or sluggish responses are noted with normal suction gage readings.

③ FUEL TANK SUMP DRAINS:

Every 100 hours, remove drain plug, drain water and sediment, and reinstall plug. Safety wire plug to adjacent wing structure.

Figure 5-1 (Sheet 2 of 5).

Figure 5-1 (Sheet 3 of 5).

8 FUEL LINE DRAIN PLUG:

Every 100 hours, remove drain plug, drain water and sediment, and reinstall plug. Safety wire plug to adjacent fuselage structure.

9 BRAKE MASTER CYLINDERS:

Every 100 hours, check fluid level in brake master cylinders. Fill with MIL-H-5606 hydraulic fluid.

10 SHIMMY DAMPENER:

Every 100 hours, check fluid level in shimmy dampener. Fill with MIL-H-5606 hydraulic fluid. See Service Manual for detailed instructions.

18 SUCTION RELIEF VALVE INLET SCREEN:

Every 100 hours, check inlet screen for dirt or obstructions. Remove screen and clean with compressed air or wash with Stoddard solvent (Fed. Spec. P-S-661).

19 VACUUM SYSTEM OIL SEPARATOR:

Every 100 hours, remove separator and flush with Stoddard solvent (Fed. Spec. P-S-661); then dry with compressed air and reinstall.

 **500 HOURS**
6 WHEEL BEARINGS:

Repack with MIL-G-7711 or a good grade of wheel bearing grease at first 100 hours, 500 hours thereafter; oftener if more than the usual amount of water, mud, ice or snow is encountered.

Figure 5-1 (Sheet 4 of 5).

 **AS REQUIRED**
4 GROUND SERVICE RECEPTACLE (OPT):

Connect to 12-volt, DC, negative-ground power unit for cold weather starting and lengthy ground maintenance of the electrical system. Refer to Section 3, paragraph "STARTING ENGINE" for position of master switch when using various types of power sources.

7 TIRES:

Maintain pressure of 26 psi on the nosewheel and 23 psi on the main wheels. Remove oil and grease from tires with soap and water; periodically inspect them for cuts, bruises and wear.

11 NOSE GEAR SHOCK STRUT:

Keep strut inflated and filled with MIL-H-5606 hydraulic fluid. See Service Manual for detailed instructions.

The military specifications listed are not mandatory, but are intended as guides in choosing satisfactory materials. Products of most reputable manufacturers meet or exceed these specifications.

Figure 5-1 (Sheet 5 of 5).

Notes

Section 6



Operational Data

The Operational Data shown on the following pages are compiled from actual tests with airplane and engine in good condition and using average piloting technique and best power mixture. You will find this data a valuable aid when planning your flights. However, inasmuch as the number of variables included precludes great accuracy, an ample fuel reserve should be provided. The range performance shown makes no allowance for wind, navigational error, pilot technique, warm-up, take-off, climb, etc. All of these factors must be considered when estimating reserve fuel.

To realize the maximum usefulness from your airplane, take advantage of the high cruising speeds. However, if range is of primary importance, it may pay you to fly at a low cruising RPM thereby increasing your range and allowing you to make the trip non-stop with ample fuel reserve. Use the range tables on the following pages to solve flight planning problems of this nature.

Range and endurance figures shown in the (172) charts are based on flight test using McCauley 1C172/EM 7653 propeller. Charts for the (P172) are based on flight test using McCauley 2A31C21/84S propeller. Other conditions of the tests are shown in the chart headings. Allowances for fuel reserve, headwinds, take-offs, and climb, and variations in mixture leaning technique should be made and are in addition to those shown on the charts. Other indeterminate variables such as carburetor metering-characteristics, engine and propeller conditions, and turbulence of atmosphere may account for variations of 10% or more in maximum range.

AIRSPEED CORRECTION TABLE

FLAPS	MODEL (172)														
	IAS	40	50	60	70	80	90	100	110	120	130	140	150		
FLAPS UP	CAS	52	57	64	72	80	89	98	108	117	127	136			
	CAS	49	54	63	72	81	91	100							
FLAPS DOWN	MODEL (P172)														
	CAS	•	56	60	67	75	85	96	106	117	127	137	148		
FLAPS DOWN	CAS	•	53	60	68	78	88	98							

Figure 6-1.

POWER OFF STALLING SPEEDS MPH - CAS

MODEL	CONDITION	ANGLE OF BANK				
		0°	20°	40°	60°	
(172) 2300 LBS. GROSS WEIGHT	FLAPS UP	57	59	65	81	
	FLAPS 10°	52	54	59	74	
	FLAPS 40°	49	51	56	69	
(P172) 2500 LBS. GROSS WEIGHT	FLAPS UP	62	63	70	87	
	FLAPS 10°	57	58	65	80	
	FLAPS 40°	54	55	61	76	

Figure 6-2.

TAKE-OFF DATA

TAKE-OFF DISTANCE FROM HARD SURFACE RUNWAY

MODEL	GROSS WEIGHT LBS.	IAS AT 50 FT. MPH	HEAD WIND KNOTS	@ S.L. & 59° F		@ 2500 ft. & 50° F		@ 5000 ft. & 41° F		@ 7500 ft. & 32° F	
				GROUND RUN	TO CLEAR 50' OBS.	GROUND RUN	TO CLEAR 50' OBS.	GROUND RUN	TO CLEAR 50' OBS.	GROUND RUN	TO CLEAR 50' OBS.
				(172) FLAPS UP	1700	60	0	435	780	520	920
10	290	570	355				680	430	820	535	1040
20	175	385	215				470	270	575	345	745
2000	65	0	630		1095	755	1325	905	1625	1120	2155
		10	435		820	530	1005	645	1250	810	1585
		20	275		580	340	720	425	910	595	1255
2300	70	0	865	1525	1040	1910	1255	2480	1565	3855	
		10	615	1170	750	1485	920	1955	1160	3110	
		20	405	850	505	1100	630	1480	810	2425	
(P172) FLAPS 10°	1900	61	0	320	715	380	820	460	960	545	1115
			10	205	520	245	600	300	710	365	830
			20	110	345	140	405	175	485	220	580
	2200	65	0	445	935	535	1085	645	1290	770	1525
			10	295	690	355	810	440	970	530	1160
			20	170	475	215	565	270	690	335	835
2500	70	0	600	1205	720	1420	875	1715	1050	2080	
		10	405	905	455	1075	610	1315	745	1610	
		20	250	640	310	770	390	955	485	1190	

Note: Increase distance 10% for each 25°F above standard temperature for particular altitude.

Figure 6-3.

MODEL	GROSS WEIGHT LBS.	③ S.L. & 59° F			④ 5000 FT & 41° F			⑤ 10,000 FT & 23° F			⑥ 15,000 FT & 5° F		
		BEST CLIMB IAS MPH	RATE OF CLIMB FT/MIN.	GALS. OF FUEL USED	BEST CLIMB IAS MPH	RATE OF CLIMB FT/MIN.	GALS. OF FUEL USED	BEST CLIMB IAS MPH	RATE OF CLIMB FT/MIN.	GALS. OF FUEL USED	BEST CLIMB IAS MPH	RATE OF CLIMB FT/MIN.	GALS. OF FUEL USED
(172)	1700	75	1085	1.0	73	825	1.9	71	570	2.9	70	315	4.4
	2000	77	840	1.0	76	610	2.2	74	380	3.6	73	155	6.3
	2300	80	645	1.0	78	435	2.6	77	230	4.8	76	22	11.5
(P172)	1900	79	1300	1.3	78	1040	2.3	76	775	3.3	74	515	4.6
	2200	82	1040	1.3	81	805	2.6	80	570	3.9	79	335	5.8
	2500	85	830	1.3	84	615	2.9	83	400	4.8	82	185	7.7

Note: Flaps up, full throttle (2400 RPM, P172), and mixture leaned for smooth operation about 5000 ft. Fuel used includes warm-up and take-off allowance.

Figure 6-4.

CRUISE & RANGE PERFORMANCE — 172 SKYHAWK —							Gross Weight- 2300 Lbs. * Standard Conditions * Zero Wind * Lean Mixture * 36 Gal. of Fuel (No Reserve)
NOTE: Maximum cruise is normally limited to 75% power. For standard 172 performance, subtract 1 MPH from the higher cruise speeds shown.							
ALT.	RPM	% BHP	TAS MPH	GAL. / HOUR	ENDR. HOURS	RANGE MILES	
2500	2700	93	138	10.5	3.4	470	
	2600	84	131	9.5	3.8	495	
	2500	75	125	8.5	4.2	530	
	2400	67	119	7.6	4.7	560	
	2300	59	113	6.8	5.3	595	
	2200	52	106	6.2	5.8	615	
	2100	46	100	5.7	6.4	635	
5000	2700	87	136	9.8	3.7	500	
	2600	78	130	8.8	4.1	525	
	2550	74	127	8.4	4.3	550	
	2500	70	124	7.9	4.5	560	
	2400	62	118	7.1	5.1	600	
	2300	55	111	6.4	5.6	625	
	2200	49	105	5.9	6.1	640	
2100	44	98	5.5	6.4	640		
7500	2650	77	132	8.7	4.2	550	
	2600	73	129	8.2	4.3	560	
	2500	65	123	7.4	4.9	600	
	2400	58	116	6.7	5.3	620	
	2300	52	110	6.1	5.9	650	
	2200	47	103	5.7	6.4	655	
	2100	42	97	5.3	6.7	655	
10,000	2600	68	128	7.7	4.7	605	
	2500	61	121	7.0	5.2	625	
	2400	55	115	6.4	5.6	645	
	2300	49	108	5.9	6.1	655	
	2200	45	102	5.5	6.6	670	
	2100	41	96	5.2	6.8	655	
	12,500	2600	63	126	7.2	5.0	630
2500		57	120	6.6	5.4	650	
2400		52	113	6.1	5.9	670	
2300		47	107	5.7	6.3	670	
2200		43	101	5.4	6.6	670	
							670

Figure 6-5.

SKYHAWK POWERMATIC CRUISE & RANGE PERFORMANCE



Standard Conditions • Zero Wind • Lean Mixture
41.5 Gal. of Fuel (No Reserve) • Gross Weight-2500 Lbs.

2500
Feet

NOTE: For 172 Powermatic performance, subtract 2 MPH from the higher cruise speeds shown.

PROP. RPM	MP	% BHP	TAS MPH	GAL./ HOUR	ENDR. HOURS	RANGE MILES
2250	23	72.0	132.0	10.30	4.00	530
	22	68.0	128.0	9.80	4.30	545
	21	63.0	124.0	9.20	4.50	565
	20	59.0	120.0	8.60	4.80	580
2200	23	70.0	131.0	10.10	4.10	535
	22	66.0	127.0	9.50	4.40	555
	21	62.0	123.0	9.00	4.60	570
	20	57.0	118.0	8.40	5.00	585
2100	23	66.0	127.0	9.60	4.30	550
	22	62.0	123.0	9.00	4.60	565
	21	58.0	119.0	8.50	4.90	580
	20	53.0	114.0	8.00	5.20	595
2000	19	45.0	101.0	6.90	6.00	605
	18	41.0	92.0	6.40	6.50	595
	17	36.0	80.0	5.80	7.20	575
	16	32.0	66.0	5.20	8.00	530

Figure 6-6 (Sheet 1 of 5).

SKYHAWK POWERMATIC CRUISE & RANGE PERFORMANCE

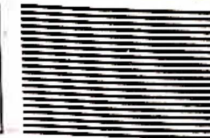

Standard Conditions • Zero Wind • Lean Mixture
41.5 Gal. of Fuel (No Reserve) • Gross Weight-2500 Lbs.

5000
Feet

NOTE: For 172 Powermatic performance, subtract 2 MPH from the higher cruise speeds shown.

PROP. RPM	MP	% BHP	TAS MPH	GAL./ HOUR	ENDR. HOURS	RANGE MILES
2250	23	75.0	137.0	10.60	3.90	535
	22	70.0	133.0	10.00	4.10	550
	21	65.0	129.0	9.40	4.40	565
	20	61.0	124.0	8.90	4.70	580
2200	23	73.0	135.0	10.40	4.00	540
	22	68.0	132.0	9.80	4.20	555
	21	64.0	127.0	9.20	4.50	575
	20	59.0	123.0	8.70	4.80	585
2100	23	69.0	132.0	9.90	4.20	555
	22	64.0	128.0	9.30	4.50	570
	21	60.0	124.0	8.80	4.70	585
	20	56.0	118.0	8.20	5.10	595
2000	19	47.0	106.0	7.20	5.80	605
	18	43.0	97.0	6.70	6.20	600
	17	38.0	85.0	6.10	6.80	585
	16	34.0	72.0	5.50	7.60	545

Figure 6-3 (Sheet 2 of 5).

SKYHAWK POWERMATIC CRUISE & RANGE PERFORMANCE

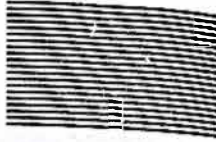

Standard Conditions • Zero Wind • Lean Mixture

7500

41.5 Gal. of Fuel (No Reserve) • Gross Weight-2500 Lbs.

Feet

NOTE: For 172 Powermatic performance, subtract 2 MPH from the higher cruise speeds shown.

PROP. RPM	MP	% BHP	TAS MPH	GAL./ HOUR	ENDR. HOURS	RANGE MILES
2250	22	72.0	138.0	10.30	4.00	555
	21	68.0	134.0	9.70	4.30	570
	20	63.0	129.0	9.10	4.60	585
	19	58.0	123.0	8.50	4.90	600
2200	22	71.0	136.0	10.10	4.10	560
	21	66.0	132.0	9.50	4.40	575
	20	61.0	127.0	8.90	4.70	590
	19	57.0	121.0	8.40	5.00	605
2100	22	67.0	133.0	9.60	4.30	575
	21	62.0	128.0	9.00	4.60	590
	20	58.0	123.0	8.50	4.90	600
	19	53.0	117.0	7.90	5.20	610
2000	19	50.0	111.0	7.50	5.50	610
	18	45.0	102.0	7.00	6.00	605
	17	41.0	91.0	6.40	6.50	590
	16	36.0	77.0	5.80	7.20	555

Figure 6-6 (Sheet 3 of 5).

SKYHAWK POWERMATIC CRUISE & RANGE PERFORMANCE

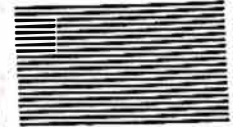

Standard Conditions • Zero Wind • Lean Mixture

10,000

41.5 Gal. of Fuel (No Reserve) • Gross Weight-2500 Lbs.

Feet

NOTE: For 172 Powermatic performance, subtract 2 MPH from the higher cruise speeds shown.

PROP. RPM	MP	% BHP	TAS MPH	GAL./ HOUR	ENDR. HOURS	RANGE MILES
2250	20	65.0	134.0	9.40	4.40	590
	19	60.0	128.0	8.80	4.70	605
	18	55.0	121.0	8.20	5.10	615
	17	51.0	113.0	7.60	5.50	615
2200	20	64.0	132.0	9.20	4.50	595
	19	59.0	126.0	8.60	4.80	605
	18	54.0	119.0	8.00	5.20	615
	17	49.0	110.0	7.40	5.60	615
2100	20	60.0	128.0	8.80	4.70	605
	19	55.0	121.0	8.20	5.10	615
	18	51.0	113.0	7.60	5.40	615
	17	46.0	104.0	7.10	5.90	610
2000	18	47.0	107.0	7.20	5.70	610
	17	43.0	96.0	6.70	6.20	600
	16	38.0	83.0	6.10	6.90	565
	15	34.0	66.0	5.40	7.70	505

Figure 6-6 (Sheet 4 of 5).

SKYHAWK POWERMATIC CRUISE & RANGE PERFORMANCE



Standard Conditions • Zero Wind • Lean Mixture
41.5 Gal. of Fuel (No Reserve) • Gross Weight-2500 Lbs.

15,000
Feet

NOTE: For 172 Powermatic performance, subtract 2 MPH from the higher cruise speeds shown.

PROP. RPM	MP	% BHP	TAS MPH	GAL./ HOUR	ENDR. HOURS	RANGE MILES
2250	17	55.0	123.0	8.10	5.10	625
	16	50.0	112.0	7.50	5.50	
	15	45.0	99.0	6.90	6.00	
2200	17	53.0	120.0	8.00	5.20	625
	16	48.0	109.0	7.40	5.70	
	15	43.0	95.0	6.70	6.20	
2100	17	50.0	113.0	7.60	5.50	620
	16	45.0	101.0	7.00	5.90	
	15	41.0	86.0	6.40	6.50	
2000	17	47.0	106.0	7.20	5.80	610
	16	43.0	93.0	6.60	6.30	
	15	38.0	77.0	6.00	6.90	

Figure 6-6 (Sheet 5 of 5).

LANDING DATA

LANDING DISTANCE ON HARD SURFACE RUNWAY, NO WIND

MODEL	GROSS WEIGHT LBS.	APPROACH IAS MPH	@ S.L. & 59° F		@ 2500 ft. & 50° F		@ 5000 ft. & 41° F		@ 7500 ft. & 32° F	
			GROUND ROLL	TO CLEAR 50' OBS.	GROUND ROLL	TO CLEAR 50' OBS.	GROUND ROLL	TO CLEAR 50' OBS.	GROUND ROLL	TO CLEAR 50' OBS.
(172)	1700	55	385	1030	415	1080	445	1130	480	1185
	2000	60	450	1140	485	1195	525	1255	565	1320
	2300	65	520	1250	560	1310	605	1385	650	1455
(P172)	1900	60	500	980	520	1030	550	1080	580	1140
	2200	64	560	1100	590	1155	620	1220	660	1290
	2500	69	610	1200	640	1260	685	1335	725	1410

Note: Reduce landing distance 10% for each 5 knot headwind. Flaps 40° and power off.

Figure 6-7.

Notes

Section 7



Optional Systems

This section contains a description, operating procedures, and performance data (when applicable) for the "major item" optional equipment systems in your airplane. Not all optional equipment is discussed here, rather it is those installations whose complexity and function is such that a detailed coverage is necessary for efficient utilization of the system. Optional equipment of a more simple nature is discussed in other portions of this manual.

AUXILIARY FUEL TANK SYSTEM

An optional auxiliary fuel tank system (figure 7-1) is available to increase the airplane operating range. System components include an 18 gallon fuel tank (17.55 gallons usable) installed on the baggage compartment floor, an electric fuel transfer pump behind the tank, an electrically-operated fuel quantity indicator and fuel transfer pump switch on the instrument panel, a fuel tank filler provision on the right side of the fuselage, a fuel tank sump drain valve at the front of the tank on the bottom of the fuselage, and the necessary plumbing.

The auxiliary fuel system is connected to the right main fuel tank plumbing above the right cabin door.

AUXILIARY FUEL SYSTEM OPERATION.

To operate the auxiliary fuel system, proceed as follows:

Prior to flight:

- (1) Turn on master switch and check fuel quantity indicator for reading.
- (2) Momentarily pull on transfer pump switch and listen for pump operation. Turn off master switch.
- (3) Check quantity of fuel in tank for agreement with fuel quantity indicator. Fill tank for anticipated requirements.
- (4) Drain small amount of fuel from fuel tank drain valve to check for

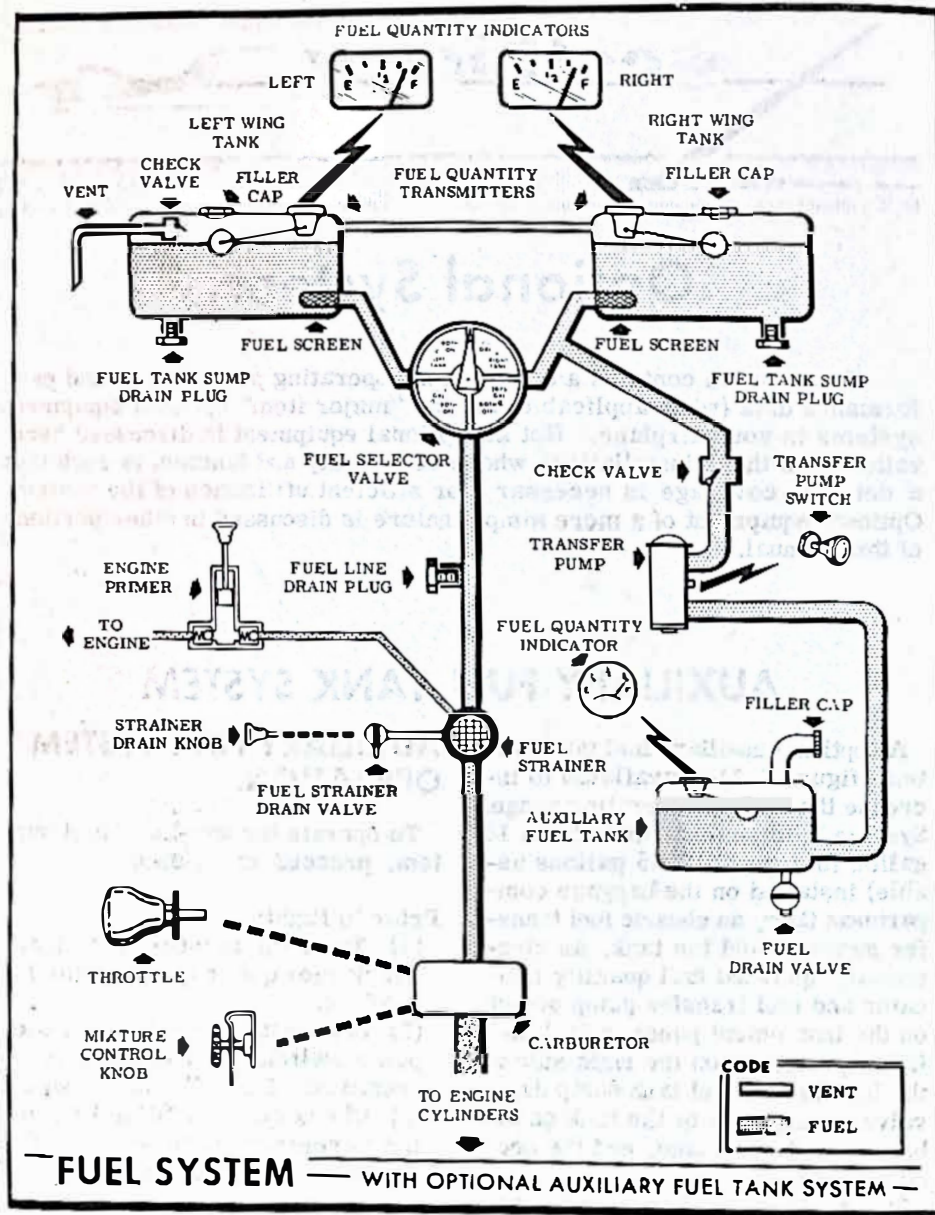

Figure 7-1.

possible water and sediment.

During flight:

- (1) Take-off, climb and land with fuel selector valve handle set "BOTH ON" for maximum safety.
- (2) After leveling off at cruise altitude, switch to "RIGHT TANK" and operate from this tank until the fuel supply is exhausted.
- (3) Switch to "LEFT TANK" for operation, then pull on transfer pump switch and refill right main fuel tank from auxiliary tank. Push transfer pump switch to "OFF" when fuel transfer is completed.

NOTE

Transfer of total fuel from the auxiliary tank will take from 45 minutes to 1 hour.

- (4) Return fuel selector valve handle to "BOTH ON" position after refilling right tank, or if desired switch again to right main tank.

IMPORTANT

Do not operate the transfer pump with the fuel selector turned to either "BOTH" or "RIGHT TANK" positions. Total or partial engine stoppage will result from air being pumped into fuel lines after fuel transfer has been completed. If the pump should accidentally be turned on with the fuel selector in either of these positions, and engine stoppage occurs, the engine will restart in from 3 to 5 seconds after turning off the transfer pump as the air in the fuel line will be evacuated rapidly.

Alphabetical Index

A

- After Landing, 2-4
- Air Filter, Carburetor, 5-9
- Air Filters, Gyro Instruments, 5-9
- Airplane, Before Entering, 2-1
- Airplane File, 5-5
- Airspeed Correction Table, 6-2
- Airspeed Limitations, 4-2
- Ammeter, 1-5
- Authorized Operations, 4-1
- Auxiliary Fuel Tank System, 7-1
 - operation, 7-1
 - schematic, 7-2
- Carburetor Air Filter, 5-9
- Carburetor Air Heat Knob, 1-1
- Care,
 - interior, 5-4
 - propeller, 5-3
- Center of Gravity Moment Envelope, 4-7
- Check, Preflight, 3-1
- Climb; 2-3, 3-6
 - data, 6-4
 - maximum performance, 2-3
 - normal, 2-3
- Cold Weather Operation, 3-9
- Controls, Engine, 1-1
- Cruise - Range Performance, 6-5, 6-6, 6-7, 6-8, 6-9, 6-10
- Cruising, 2-3, 3-7

B

- Baggage, Weight, inside cover page
- Battery, 1-5, 5-9
 - solenoid, 1-5
- Before Entering Airplane, 2-1
- Before Landing, 2-3
- Before Starting Engine, 2-1
- Before Take-Off, 2-2, 3-4
- Brake Operation, Parking, 1-7
- Brake System, 1-6
 - master cylinders, 5-10

C

- Cabin Heating and Ventilating System, 1-8
- Cabin Ventilators, 1-8
- Capacity,
 - fuel, inside cover page
 - oil, inside cover page
- Carburetor, 1-3

D

- Data,
 - climb, 6-4
 - fuel quantity, 1-4
 - landing, 6-11
 - take-off, 6-3
- Dealer Follow-up System, 5-6
- Diagram,
 - electrical power distribution, 1-5
 - exterior inspection, 1-10
 - servicing, 5-7
 - taxiing, 3-3
- Dimensions,
 - internal cabin, 1-9
 - principal, iv, v
- Drain Knob, Fuel Strainer, 1-3, 1-4
- Drain Plug, Fuel Line, 1-3, 5-10
- Drain Plugs, Fuel Tank, 1-3, 5-9

E

- Electrical System, 1-4
 - battery, 1-5, 5-9
 - battery solenoid, 1-5
 - fuses, 1-6
 - generator, 1-5
 - generator warning light, 1-5, 1-6
 - power distribution diagram, 1-5
 - voltage regulator, 1-5
- Empty Weight, inside cover page
- Engine, inside cover page
 - before starting, 2-1
 - controls, 1-1
 - instrument markings, 4-3
 - operation limitations, 4-3
 - primer, 1-3
 - starting, 2-1, 3-2
- Envelope, Weight and Balance, 4-7
- Exterior Inspection Diagram, 1-10

F

- File, Airplane, 5-5
- Filter, Carburetor Air, 5-9
- Filters, Gyro Instrument Air, 5-9
- Fuel Specification and Grade, 5-7
- Fuel System, 1-2
 - capacity, inside cover page
 - line drain plug, 1-3, 5-10
 - primer, 1-3
 - quantity data, 1-4
 - quantity indicators, 1-3, 1-4
 - quantity transmitters, 1-3
 - schematic, 1-3
 - selector valve, 1-2, 1-3
 - strainer drain knob, 1-3, 1-4
 - strainer, 1-3, 5-8
 - tank fillers, 1-3, 5-8
 - tank sump drains, 1-3, 5-9

Fuses, 1-4

Index-2

G

- Generator, 1-5
- Generator Warning Light, 1-5, 1-6
- Gross Weight, inside cover page
- Ground Handling, 5-1
- Ground Service Receptacle, 1-5, 5-11
- Gyro Instrument Air Filter, 5-9

H

- Handle, Starter, 1-2
- Heating and Ventilating System, 1-8
- Hydraulic Fluid Specification, 5-7

I

- Ignition-Starter Switch, 1-2, 1-5
- Indicator,
 - fuel quantity, 1-3, 1-4
 - stall warning, 1-6
- Inspection Diagram, Exterior, 1-10
- Inspection Service-Periods, 5-4
- Instrument Markings, 4-3
- Interior Care, 5-4
- Internal Cabin Dimensions, 1-9

K

- Knob,
 - carburetor air heat, 1-1
 - engine primer, 1-3
 - fuel strainer drain, 1-3, 1-4
 - mixture control, 1-1, 1-3
 - parking brake, 1-7

L

- Landing, inside cover page, 3-8
 - after, 2-4
 - before, 2-3

- data, 6-11
- normal, 2-4
- Let-Down, 2-3
- Light,
 - generator warning, 1-5, 1-6
 - landing, 1-6
- Limitations, Airspeed, 4-2
- Limitations, Engine Operating, 4-3
- Loading Problem, Sample, 4-5, 4-6
- Lubrication and Servicing, 5-6

M

- Maneuvers, Normal Category, 4-1
- Maneuvers, Utility Category, 4-1
- Master Switch, 1-5
- Maximum Performance Climb, 2-3
- Maximum Performance
 - Take-off, 2-2
- Mixture Control Knob, 1-1, 1-3
- Mooring Your Airplane, 5-1

N

- Normal Category, Maneuvers, 4-1
- Normal Climb, 2-3
- Normal Landing, 2-4
- Normal Take-off, 2-2
- Nose Gear,
 - shock strut, 5-7, 5-11
 - torque links, 5-7, 5-9

O

- Oil Specification and Grade, 5-7
- Oil System,
 - capacity, inside cover page
 - oil filler and dipstick, 5-7, 5-8
 - oil screens, 5-9

- sump drain, 5-9
- Operating Limitations, Engine, 4-3
- Operation, Auxiliary Fuel
 - Tank System, 7-1
- Operation, Cold Weather, 3-9
- Operation, Parking Brake, 1-7
- Operations Authorized, 4-1

P

- Painted Surfaces, 5-3
- Parking Brake Operation, 1-7
- Performance, Specifications, inside cover page
- Power Loading, inside cover page
- Pre-flight Check, 3-1
- Primer Engine, 1-3
- Principal Dimensions, iv, v
- Propeller, inside cover page
 - care, 5-3
 - control, 1-1

Q

- Quantity Data, Fuel, 1-4
- Quantity Indicators, Fuel, 1-3, 1-4
- Quantity Transmitters, Fuel, 1-3

R

- Range, inside cover page
- Range - Cruise Performance, 6-5 thru 6-10
- Rate of Climb, inside cover page
- Receptacle, Ground Service, 1-5

Index-3

Alphabetical Index

S

Sample Loading Problem, 4-5, 4-6
Schematic, Auxiliary Fuel Tank System, 7-2
Schematic, Fuel System, 1-3
Selector Valve, Fuel, 1-2, 1-3
Service Ceiling; inside cover page
Servicing Diagram, 5-7
Servicing Procedures, 5-8
Shimmy Dampener, 5-10
Shock Strut, Nose Gear, 5-11
Specification and Grade,
fuel, 5-7
hydraulic fluid, 5-7
oil, 5-7
Speed, inside cover page
Stall Warning Indicator, 1-6
Stalling Speed Chart, 6-2
Stalls, 3-8
Starter, 1-5
Starter Handle, 1-2
Starter-Ignition Switch, 1-2, 1-5
Starting Engine, 2-1, 3-2
Storage, 5-2
Strainer, Fuel, 1-3, 5-8
Strainer Drain Knob, Fuel, 1-3, 1-4
Suction Relief Valve Inlet
Screen, 5-10
Sump Drain Plugs, Fuel Tank,
1-3, 5-9
Surfaces, Painted, 5-3
Switch, Master, 1-5
System,
auxiliary fuel tank, 7-1
brake, 1-6
cabin heating and ventilating,
1-8
dealer follow-up, 5-6
electrical, 1-4
fuel, 1-2

T

Table of Contents, iii
Take-off, inside cover page,
2-2, 3-5
before, 2-2, 3-4
data, 6-3
maximum performance, 2-2
normal, 2-2
Taxiing, 3-2
diagram, 3-3
Throttle, 1-1, 1-3
Tie-down Procedure, 5-1
Tires, 5-11
Torque Links, Nose Gear, 5-9

U

Utility Category, Maneuvers, 4-1

V

Vacuum System Oil Separator, 5-10
Valve, Fuel Selector, 1-2, 1-3
Ventilators, Cabin, 1-8
Voltage Regulator, 1-5

W

Warning Light, Generator, 1-5, 1-6
Weight,
empty, inside cover page
gross, inside cover page
Weight and Balance, 4-3
loading graph, 4-6
moment envelope, 4-7
sample loading problem, 4-5,
4-6
Wheel Bearings, 5-10
Windshield and Windows, 5-2

WARRANTY

■ The Cessna Aircraft Company warrants each new aircraft manufactured by it to be free from defects in material and workmanship under normal use and service, provided, however, that this warranty is limited to making good at The Cessna Aircraft Company's factory any part or parts thereof which shall, within six (6) months after delivery of such aircraft to the original purchaser, be returned to Cessna with transportation charges prepaid, and which upon Cessna's examination shall disclose to its satisfaction to have been thus defective; this warranty being expressly in lieu of all other warranties expressed or implied and all other obligations or liabilities on the part of Cessna, and Cessna neither assumes nor authorizes any other person to assume for it any other liability in connection with the sale of its aircraft.

■ This warranty shall not apply to any aircraft which shall have been repaired or altered outside Cessna's factory in any way so as, in Cessna's judgment, to affect the aircraft's stability or reliability, or which aircraft has been subject to misuse, negligence or accident.

WARRANTY

Servicing Requirements



FUEL:

AVIATION GRADE -- 80/87 MINIMUM GRADE

CAPACITY: (172) (P172)
EACH TANK 19.5 gal. 26.0 gal.

ENGINE OIL:

AVIATION GRADE -- SAE 40 ABOVE 40° F.
SAE 20 BELOW 40° F.

CAPACITY: (172) (P172)
ENGINE SUMP-----8 qts 10 qts
(Do not operate with less than 6 quarts)

HYDRAULIC FLUID:

MIL-H-5606 HYDRAULIC FLUID
(Shimmy Dampener and Brake Master Cylinders)

TIRE PRESSURES:

NOSE WHEEL----- 26 psi
MAIN WHEELS----- 23 psi

 Cessna. _____

"LOOK FOR THE RED AND
BLUE CESSNA PENNANTS
FOR THAT EXTRA SERVICE
WHERE IT COUNTS WHEN
YOU NEED IT".

CESSNA AIRCRAFT COMPANY



WICHITA, KANSAS

N 20914

 Cessna.

1963

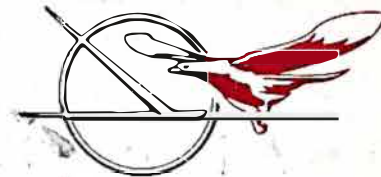

MODEL
172D,
SKYHAWK
AND
POWERMATIC
SERIES

OWNER'S
MANUAL